

5/2 INTERNAL PILOT OPERATED, SINGLE/ DOUBLE SOLENOID, SUBBASE MOUNTED VALVE



HORIZONTAL CABLE ENTRY
ALUMINIUM CAST ENCLOSURE
WEATHER PROOF Type 16, 19
EXPLOSION PROOF Type 58, 58LT, 67



MULTI PIN CONNECTOR
STEEL ENCLOSURE
WEATHER PROOF Type 70



HORIZONTAL CABLE ENTRY
STAINLESS STEEL CAST ENCLOSURE
WEATHER PROOF Type 16-CO, 19-CO,
EXPLOSION PROOF Type 58-CO, 58LT-CO,
37-CO, 39-CO, 67-CO



DIN PLUG CONNECTOR
MOULDED ENCLOSURE
WEATHER PROOF Type 22



HORIZONTAL CABLE ENTRY
ALUMINIUM CAST ENCLOSURE
EXPLOSION PROOF Type 37, 39



DIN PLUG CONNECTOR
STEEL ENCLOSURE
WEATHER PROOF Type 25
EXPLOSION PROOF Type 65CR



BOTTOM CABLE ENTRY
ALUMINIUM CAST ENCLOSURE
WEATHER PROOF Type 17
EXPLOSION PROOF Type 87, 66, 71



BOTTOM CABLE ENTRY
STAINLESS STEEL CAST ENCLOSURE
WEATHER PROOF Type 17-CO
EXPLOSION PROOF Type 87-CO, 66-CO,
71-CO

**Interchangeable across
Voltage/ Current range without
affecting performance of the Valve**



Engineering For The Future

5/2 INTERNAL PILOT OPERATED, SINGLE/ DOUBLE SOLENOID, SUBBASE MOUNTED VALVE

FEATURES

- Bubble tight shut OFF
- Can be used as 3/2 NC/ NO by plugging port 4/2
- Ideally suited where speed control by blocking exhaust is desired
- Suitable for high speed cycling, speed up to 500 cycles/ min
- Life >20 million cycles

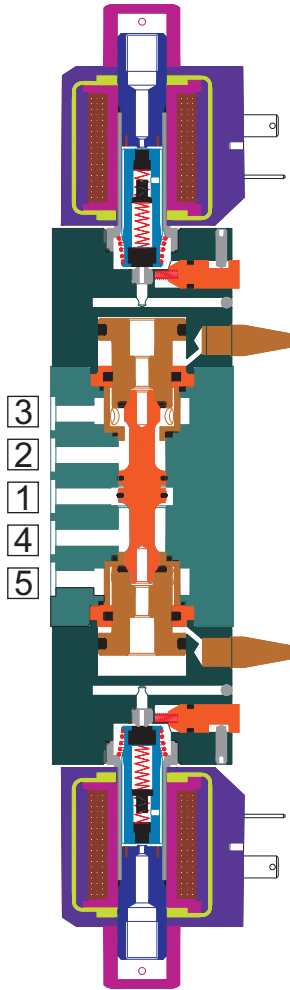

More windings :
 -Low temperature rise
 -Improved Insulation

Floating seat for longer seat life and for stuck free movement of the plunger

Non Sliding Gap between Plunger and Core tube for stuck free movement of the plunger

Profiled shaped Nozzle for Longer seat life

No stress on Seat Seal while seating
 -For longer life

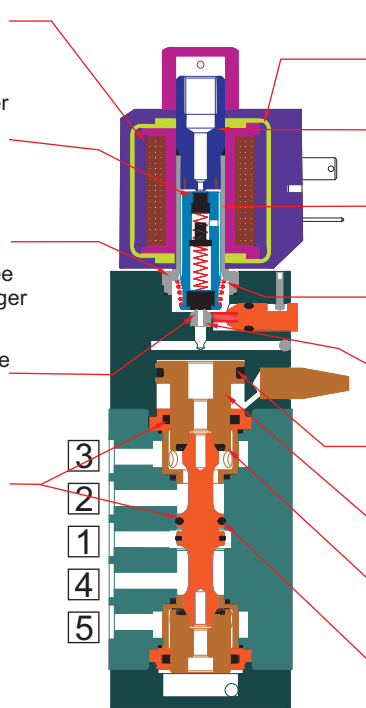

'O' Shape core for efficient magnetic linkage
 - Lower pulling force

Improved Operator design resulting in optimal Power

SS 430 Plated Plunger
 - High resistance to corrosion

Self aligning Spring
 -Maintaining axis of Plunger helping free movement of Plunger in Core Tube

Larger Nozzle Diameter for higher flow factor

Seals do not cross holes while changing ports
 -For longer life

Well supported Poppet assembly
 -Longer life and proper sealing

Lower Stroke
 -For quick operation
 -For higher flow rate

Positive Sealing for leak tightness
 -For longer Life

WEIGHT IN kg. (Appx.)

Valve

Valve type - Orifice	Al	SS
51445A-6	0.90	1.70
51445-12	1.40	3.30
51445V01-25	4.00	11.00
57445A-6	0.95	2.30
57445-12	1.75	4.50
57445V01-25	5.20	13.00

Solenoid

Type	Size		Type	Size	Enclosure	
					Al	SS
25, 65CR	I	0.25	16, 19, 37,	I	0.55	1.20
	II	0.45	39, 58,	II, IV	0.85	1.70
	III	0.40	58LT, 67	III	0.60	1.50
	IV	0.50	17, 66,	II, IV	1.00	1.65
			71, 87	III	0.90	1.50

VOLTAGE VARIATION

(For Continuous Duty)

Rated Voltage	Operating Voltage
6	4.8V to 7.2V
12	9.6V to 14.4V
24	19.2V to 28.8V
48	38.4V to 57.6V
110 to 120	88V to 132V
220/ 230/ 240	176V to 264V
256	205V to 280V

5/2 INTERNAL PILOT OPERATED, SINGLE/ DOUBLE SOLENOID, SUBBASE MOUNTED VALVE

TYPE	PRESSURE
57445	2 - 10 bar
57445LW	2 - 10 bar
57445L4	2 - 8 bar
57445IS	2 - 11 bar
57445IR	2 - 8 bar

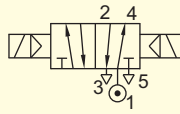

TYPE	PRESSURE
51445	2 - 10 bar
51445LW	2 - 10 bar
51445L4	2 - 8 bar
51445IS	2 - 11 bar
51445IR	2 - 8 bar

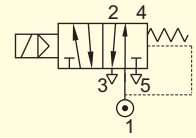

WETTED PARTS

Code	※	B5
Body	Anodized Aluminium	SS 316
Internals	Aluminium, Brass and SS 316	SS 316
Guide	SS 304	
Shadow-Ring	Copper	
Plunger, Insert	SS 430	
Spring	SS 302	
Fasteners	SS 304	
Seat, Seals	NBR, Viton	



APPLICATION

Operation of double acting Cylinder/ Actuator

POWER

Power	Normal		Low		Ex ia	
	6W/ 8W	2W	0.4W	Type : 66	Type : 65CR, 67, 71	
Type	51445, 51445A, 57445, 57445A	51445LW, 51445AW, 57445LW, 57445AW	51445L4, 51445A4, 57445L4, 57445A4	51445, 51445A, 57445, 57445A	51445IS, 57445IS, 51445IR, 57445IR, 51445AI, 51445AR, 57445AI, 57445AR	
Size	I/ III	III	III	III	III	

SPARES

SPARE KIT	CODE
Seal Kit : Oring Set (Only for Intrinsically Safe Valve)	P98
Seal Kit : Oring Set and Plunger Assembly	98
Repair Kit : All Components except Body Cover and Solenoid	99
Repair Kit : All Components except Body and Solenoid (for Intrinsically Safe Valve)	99
Solenoid Kit : Solenoid, Gasket	34

PORT CONNECTION

VALVE TYPE	MODE	INLET	OUTLET	OUTLET	EXHAUST	EXHAUST	PILOT EXHAUST
51445, 51445A, 51445AW, 51445LW, 51445A4, 51445L4, 51445AI, 51445IS, 51445AR, 51445IR	Single Solenoid	1	2	4	3	5	6
57445, 57445A, 57445AW, 57445LW, 57445A4, 57445L4, 57445AI, 57445IS, 57445AR, 57445IR	Double Solenoid	1	2	4	3	5	6

Contact Rotex for
• Any other Temperature Range, Media and Application

5/2 INTERNAL PILOT OPERATED, SINGLE/ DOUBLE SOLENOID, SUBBASE MOUNTED VALVE

SPECIFICATION

VALVE	
Valve Type	5/2 Internal pilot operated, Single / Double Solenoid, Subbase mounted Valve
Body Material	Aluminium/ Stainless Steel 316
Port Connection	Sub Base
Orifice	6mm/ 12mm/ 25mm
Seals	NBR/ Viton
Manual Override	Stayput/ Momentary/ Without Manual Override
Flow factor Orifice - kv/ Kv/ Cv	6mm-12/ 0.72/ 0.84 12mm-50/ 3/ 3.5 25mm - 110/6.6/7.7 (Port 1")
Media	Air
⑬ Ambient, Fluid Temperature	-25 °C to 75 °C, Optionally -60 °C to 150 °C
Response ON/ OFF	≤ 50ms/ ≤ 90ms
Pressure	2-8 bar, 2-10 bar, 2-11 bar

SOLENOID	
Voltage-Current	DC 12V, 24V, 48V, 110V, 220V, 256V
	AC (50Hz/ 60Hz) 24V, 110V, 120V, 230V, 240V
	AC/ DC (50Hz/ 60Hz/ DC) 24V, 110V, 120V, 230, 240V
Power	8W/ 6W/ 2W/ 0.4W
Protection	Weather Proof IP67 Explosion Proof Ex d, Ex ia, Ex e mb IIC T6/ T5/ T4 IP67
Cable Entry	Pg 9/ M20X1.5/ 1/2" NPT/ M25X1.5

ORDERING CODE Solenoid Valve (Valve Code + Solenoid Code)

VALVE TYPE 51445A	-	SIL SL	-	SUFFIX *	-	ORIFICE 6	-	PORT CONNECTION SB	-	BODY INTERNAL B5	-	MANUAL OVERRIDE M0	-	SEAL S2G	-	⑭ MEDIA *
ACCESSORIES VALVE, PORT A1	+	SIZE I	-	VOLTAGE, CURRENT 24V DC	-	ENCLOSURE 39	-	⑦ MTL *	-	SPECIAL *	-	POWER *	-	INSULATION H	-	APPROVAL 01
SIL SL	-	ACCESSORIES SOLENOID B5														

ORDERING CODE Valve Spare Kit

SPARE KIT 99	-	VALVE TYPE 51445A	-	SIL SL	-	SUFFIX *	-	ORIFICE 6	-	PORT CONNECTION SB	-	BODY INTERNAL B5	-	MANUAL OVERRIDE M0
SEAL S2G	-	ACCESSORIES VALVE, PORT A1												

ORDERING CODE Spare Solenoid

SOLENOID KIT 34	-	SIZE I	-	VOLTAGE, CURRENT 24V DC	-	ENCLOSURE 39	-	⑦ MTL *	-	SPECIAL *	-	POWER *	-	INSULATION H	-	APPROVAL 01
SIL SL	-	ACCESSORIES SOLENOID B5														

ORDERING CODE Manifold

MANIFOLD TYPE MF008	-	SPACE 6	-	PORT CONNECTION * BSP R NPT	-	MANIFOLD MATERIAL * ALUMINIUM	-	ACCESSORIES Refer to valve Accessories on Page 10	-	* VALVE 51445 57445
NUMBER OF VALVE 3	-	SOLENOID CODE Refer to Accessories on Page 6 and 7	-	ACCESSORIES SOLENOID Refer to Accessories Solenoid on Page 10						

Note : * Specify Complete Valve Code

5/2 INTERNAL PILOT OPERATED, SINGLE/ DOUBLE SOLENOID, SUBBASE MOUNTED VALVE

VALVE TYPE-ORIFICE		
CODE		DESCRIPTION
SINGLE SOLENOID SPRING RETURN	DOUBLE SOLENOID	
NORMAL POWER		
51445A-6	57445A-6	2-10 bar, 8 Watt
51445-12	57445-12	2-10 bar, 8 Watt
51445V01-25	57445V01-25	2-10 bar, 8 Watt
LOW POWER		
51445AW-6	57445AW-6	2-10 bar, 2 Watt
51445LW-12	57445LW-12	2-10 bar, 2 Watt
51445V01LW-25	57445V01LW-25	2-10 bar, 2 Watt
⑪ 51445AW-6	⑪ 57445AW-6	2-10 bar, 0.4 Watt, Size III, Power LB04
⑪ 51445LW-12	⑪ 57445LW-12	2-10 bar, 0.4 Watt, Size III, Power LB04
⑪ 51445V01LW-25	⑪ 57445V01LW-25	2-10 bar, 0.4 Watt, Size III, Power LB04
51445A4-6	57445A4-6	2-8 bar, 0.4 Watt, Size III, Power LW0.4
51445L4-12	57445L4-12	2-8 bar, 0.4 Watt, Size III, Power LW0.4
51445V01L4-25	57445V01L4-25	2-8 bar, 0.4 Watt, Size III, Power LW0.4
INTRINSICALLY SAFE Ex ia 24V DC		
51445A-6	57445A-6	2 - 10 bar, Ex ia Enclosure Type 66
51445-12	57445-12	2 - 10 bar, Ex ia Enclosure Type 66
51445V01-25	57445V01-25	2 - 10 bar, Ex ia Enclosure Type 66
514445AI-6	574445AI-6	2 - 11 bar, Ex ia, Enclosure Type 65CR, 67, 71
514445IS-12	574445IS-12	2 - 11 bar, Ex ia, Enclosure Type 65CR, 67, 71
514445V01IS-25	574445V01IS-25	2 - 11 bar, Ex ia, Enclosure Type 65CR, 67, 71
514445AR-6	574445AR-6	2 - 8 bar, Enclosure Type 65CR, 67, 71
514445IR-12	574445IR-12	2 - 8 bar, Enclosure Type 65CR, 67, 71
514445V01IR-25	574445V01IR-25	2 - 8 bar, Enclosure Type 65CR, 67, 71

SIL CERTIFIED	
CODE	DESCRIPTION
① ✖	NO
SL	YES

SUFFIX	
CODE	DESCRIPTION
① ✖	NIL
⑧ AM	Ammonia
⑪ TC	3 Port NC
⑬ TO	3 Port NO

ORIFICE	
CODE	DESCRIPTION
6	6 mm
12	12 mm
25	25 mm

PORT CONNECTION	
CODE	DESCRIPTION
SB	SUB BASE

BODY MATERIAL	
CODE	DESCRIPTION
① ✖	ALUMINIUM
B5	SS316
B5N	SS316 NACE Compliance

MANUAL OVERRIDE		
CODE		DESCRIPTION
SINGLE SOLENOID	DOUBLE SOLENOID	
M0	M0	NIL
① ✖	-	Stayput cum Momentary
M8	① ✖	Momentary

SEAL		
CODE	GRADE, AMBIENT TEMPERATURE	MEDIA
		① ✖
① ✖	NBR, -25 °C to 75 °C	✓
S2G	VITON, -40 °C to 160 °C	✓

⑰ MEDIA	
CODE	DESCRIPTION
① ✖	Air

5/2 INTERNAL PILOT OPERATED, SINGLE/ DOUBLE SOLENOID, SUBBASE MOUNTED VALVE

SIZE-VOLTAGE CURRENT		
CODE	SIZE	COIL VOLTAGE
I-12V DC	I	12V DC
I-24V DC	I	24V DC
I-24V 50Hz	I	24V 50Hz/ 60Hz
I-110V 50Hz	I	110V 50Hz/ 120V 60Hz
I-230V 50Hz	I	230V 50Hz/ 240V 60Hz
III-12V DC	III	12V DC
III-24V DC	III	24V DC
III-24V 50Hz	III	24V 50Hz/ 60Hz
III-24V AC/ DC	III	④ 24V 50Hz/ 60Hz/ DC
III-48V DC	III	48V DC
III-110V DC	III	110V DC
III-110V 50Hz	III	110V 50Hz/ 120V 60Hz
III-110V AC/ DC	III	④ 110V 50Hz/ 60Hz/ DC 120V 50Hz/ 60Hz/ DC
III-220V DC	III	220V DC
III-230V 50Hz	III	230V 50Hz/ 240V 60Hz
III-230V AC/ DC	III	④ 220V 50Hz/ 60Hz/ DC 240V 50Hz/ 60Hz/ DC
III-256V DC	III	256V DC

ENCLOSURE TYPE	
CODE	DESCRIPTION
WEATHER PROOF TERMINAL BOX	
⑤ 22	DIN Plug Solenoid, IP 67, Cable Entry Pg9, as per DIN43650B, Size I
⑤ 25	DIN Plug Solenoid, IP 67, Cable Entry Pg9, as per DIN43650A, Size III, IV
16	Integrated Terminal box, IP 67, 1/2" NPT, -40 °C to 100 °C
19	Integrated Terminal box, IP 67, M20X1.5, -40 °C to 100 °C
17	Integrated Terminal Box, IP67, Bottom Cable Entry, M25X1.5, Size III, IV
17-MS	Integrated Terminal Box, IP67, Bottom Cable Entry, M20X1.5, Size III, IV
17-NS	Integrated Terminal Box, IP67, Bottom Cable Entry, 1/2" NPT, Size III, IV
17-A	Integrated Terminal Box, IP68, Bottom Cable Entry, M25X1.5, Size III, IV
17-MS-A	Integrated Terminal Box, IP68, Bottom Cable Entry, M20X1.5, Size III, IV
17-NS-A	Integrated Terminal Box, IP68, Bottom Cable Entry, 1/2" NPT, Size III, IV
EXPLOSION PROOF Ex d (For Gas & Dust)	
⑤ 37	Ex d IIC IP66, -40 °C TO 60 °C, 1/2" NPT
⑤ 39	Ex d IIC IP66, -40 °C TO 60 °C, M20 X 1.5
87	Ex d IIC IP67, -60 °C TO 100 °C, M25 X 1.5, Size III, IV
87-MS	Ex d IIC IP67, -60 °C TO 100 °C, M20 X 1.5, Size III, IV
87-NS	Ex d IIC IP67, -60 °C TO 100 °C, 1/2" NPT, Size III, IV
87 -A	Ex d IIC IP68, -60 °C TO 100 °C, M25 X 1.5, Size III, IV
87-MS-A	Ex d IIC IP68, -60 °C TO 100 °C, M20 X 1.5, Size III, IV
87-NS-A	Ex d IIC IP68, -60 °C TO 100 °C, 1/2" NPT, Size III, IV
FLAMEPROOF Ex e mb (For Gas & Dust)	
58	Ex e mb IIC, IP67, -40 °C TO 70 °C, M25 X 1.5
58-MS	Ex e mb IIC, IP67, -40 °C TO 70 °C, M20 X 1.5
58-NS	Ex e mb IIC, IP67, -40 °C TO 70 °C, 1/2" NPT
58LT	Ex e mb IIC, IP67, -60 °C TO 70 °C, M25 X 1.5
58LT-MS	Ex e mb IIC, IP67, -60 °C TO 70 °C, M20 X 1.5
58LT-NS	Ex e mb IIC, IP67, -60 °C TO 70 °C, 1/2" NPT
INTRINSICALLY SAFE Ex ia (For Gas & Dust)	
62	Ex ia IIC, IP67, -60 °C TO 70 °C, M25 X 1.5, Size IV, Booster Circuit
62-MS	Ex ia IIC, IP67, -60 °C TO 70 °C, M20 X 1.5, Size IV, Booster Circuit
62-NS	Ex ia IIC, IP67, -60 °C TO 70 °C, 1/2" NPT, Size IV, Booster Circuit
③ 65CR	Ex ia IIC, IP67, -60 °C TO 70 °C, Pg9, Size III, DIN Plug In Enclosure
66	Ex ia IIC, IP67, -60 °C TO 70 °C, M25 X 1.5, Size III, Booster Circuit
66MS	Ex ia IIC, IP67, -60 °C TO 70 °C, M20 X 1.5, Size III, Booster Circuit
66NS	Ex ia IIC, IP67, -60 °C TO 70 °C, 1/2" NPT, Size III, Booster circuit
67	Ex ia IIC, IP67, -60 °C TO 70 °C, M25 X 1.5, Size III
67MS	Ex ia IIC, IP67, -60 °C TO 70 °C, M20 X 1.5, Size III
67NS	Ex ia IIC, IP67, -60 °C TO 70 °C, 1/2" NPT, Size III
71	Ex ia IIC, IP67, -60 °C TO 70 °C, M25 X 1.5, Size III
71MS	Ex ia IIC, IP67, -60 °C TO 70 °C, M20 X 1.5, Size III
71NS	Ex ia IIC, IP67, -60 °C TO 70 °C, 1/2" NPT, Size III

⑦ ENCLOSURE MATERIAL	
CODE	DESCRIPTION
① ✳	Aluminium Cast Epoxy Powder Coated
CO	CF8M (Stainless Steel Cast)

SPECIAL	
CODE	DESCRIPTION
① ✳	NIL
⑦ FR	Full Rectifier with Surge Suppressor Size III, IV
②③④ LD	LED, Size III, IV
⑫ SS ⑫⑥	Surge Suppressor Size III, IV
⑩ RC	Half Rectifier with Surge Suppressor Size II, III

POWER																
			12V DC	24V DC	24V 50 Hz	24V AC/ DC	48V DC	110V DC	110V 50Hz	110V AC/ DC		230V 50Hz	220V DC	230V AC/ DC		256V DC
CODE	SIZE	POWER WATT	12V DC	24V DC	24V 50 Hz/ 60 Hz	24V 50Hz/ 60 Hz/ DC	48V DC	110V DC	110V 50Hz/ 120V 60Hz	④ 110V 50Hz/ 60Hz/ DC	④ 120V 50Hz/ 60Hz/ DC	230V 50Hz/ 240V 60Hz	220V DC	④ 220V 50Hz/ 60Hz/ DC	④ 240V 50Hz/ 60Hz/ DC	256V DC
LW2	I	2.0		✓					✓							
① ✳	I	6.0			✓				✓			✓				
① ✳	I	8.0	✓	✓												
LW0.4	III	0.4		✓												
LW2	III	2.0	✓	✓				✓		✓	✓					
① ✳	III	6.0			✓				✓			✓				
① ✳	III	8.0	✓	✓		✓	✓	✓		✓			✓	✓		
		9.0									✓				✓	✓
①																
LB04	III	0.4		✓												

INSULATION	
CODE	DESCRIPTION
① ✳	CLASS F
H	CLASS H

SIL	
CODE	DESCRIPTION
① ✳	NO
SL	YES

SERIES : 52S

5/2 INTERNAL PILOT OPERATED, SINGLE/ DOUBLE SOLENOID, SUBBASE MOUNTED VALVE

APPROVAL		9 ENCLOSURE TYPE													
CODE	DESCRIPTION	17	37	39	58	58LT	62	65CR	66	67	71	87	17A	87A	
15 ✘	CCOE/ PESO + BIS, Insulation Class H		✓	✓			✓	✓	✓	✓	✓	✓		✓	
01	CE - ATEX, Insulation Class H		✓	✓	✓	✓									
01	IEC Ex + ATEX, Insulation Class H						✓		✓	✓	✓	✓		✓	
01B	INDIAN + ATEX, Insulation Class H		✓	✓			✓		✓			✓		✓	
02	UL Recognised, for USA and Canada, Type 3, 3S, 4, 4X, 6, 6P UL file Number E 342217	✓											✓		
03	INMETRO + ATEX, Insulation Class H		✓	✓			✓		✓	✓	✓	✓		✓	
03C	IEC Ex + ATEX + IN METRO + CuTR-EAC												✓	✓	
04	CuTR- EAC + ATEX , Insulation Class H		✓	✓			✓		✓	✓	✓	✓		✓	
21 07	KOSHA + ATEX, Insulation Class H											✓		✓	
08	Ukraine, Insulation Class H						✓		✓	✓	✓	✓		✓	
25 CE	CE (Weatherproof Solenoid)	✓												✓	
30 EAC	EAC MARK	✓											✓		

Note :

- ① Do not Specify when opted for
- ② Approval Other than BIS, CCOE/ PESO, DGMS
- ③ BIS, CCOE/ PESO, DGMS Approved coil
- ④ Opt FR from special
- ⑤ Current DC, 50Hz, 60Hz
- ⑦ Do not Opt for Enclosure Type 01, 06, 22, 25
- ⑧ Select Body Material SS316 (B5), Solenoid DC or AC/DC Current
- ⑨ All variation of 17, 37, 39, 58, 58LT, 65CR, 66, 67, 71, 87 included
- ⑩ Media should be Oil free Air/ Inert Gas/ Water
- ⑪ Do not opt for 01, 06, 22, 25. In rush 2W for 100 msec, Holding 0.4W
- ⑫ Current DC
- ⑬ Ambient Temperature restricted for Enclosure Type 17, 37, 39, 58, 58LT, 65CR, 66, 67, 71, 87 to Solenoid Ambient Temperature
- ⑭ Select one or Nil Accessories from A1 to A6 for valve, B1 to B8 for port AP5A to AP5E or MF008
- ⑮ IP67 Certified by BIS, CCOE/ PESO, DGMS
- ⑰ Type 51445A, 57445A, 51445, 57445, 51445AW, 57445AW, 51445LW, 57445LW, 51445AI, 57445AI, 51445IS, 57445IS, 51445IR, 57445IR, 57445AR, 51445AR with Suffix TC (Port 4 plugged) can be used as 3 Port NC Valve
- ⑱ Type 51445A, 57445A, 51445, 57445, 51445AW, 57445AW, 51445LW, 57445LW, 51445AI, 57445AI, 51445IS, 57445IS, 51445IR, 57445IR, 57445AR, 51445AR with Suffix TO (Port 2 plugged) can be used as 3 Port NO Valve
- ⑲ Can not be opted for Enclosure Type 01, 06
- ⑳ Can be opted for Enclosure Type 01, 06, 16, 19, 22, 25
- ㉑ KOSHA certificate only for enclosure size II ≤ 20W
- ㉒ Do not Opt for Enclosure Type 01, 06, 22
- ㉓ Media Code shall be part of Ordering Code other than Default Media Type
- ㉔ For Solenoid type 25 with AC current supply, Use 50Hz with Special RC Option
- ㉕ For Intrinsically Safe Solenoid, LD (LED) can be opted with CCOE/PESO certification only

ENTITY PARAMETER

Entity Parameter	
Ui	32V DC
Ii	230mA
Pi	2.3W
Ci	0
Li	0

MINIMUM OPERATING PARAMETER

Type	66	66..LD..	65CR	67	67..LD..	71	71..LD..	65CR	67	67..LD..	71	71..LD..
Minimum Voltage (V)	10	10	11	11	11	11	11	14	14	15	14	14
Minimum Current (mA)	19.5	21	19	19	22	19	22	25	25	28	25	28
Minimum Power (W)	0.195	0.21	0.21	0.21	0.24	0.21	0.24	0.35	0.35	0.42	0.35	0.42
LED	No	Yes	No	No	Yes	No	Yes	No	No	Yes	No	Yes
Pressure (bar)	As per Solenoid Valve rating		Maximum 8.0					Maximum 11.0				

RESPONSE ON TIME FOR SOLENOID TYPE 66, 66..LD..

Voltage (V)	10	11	12	14	18	22	24	26	30	32	Current (mA)	18.5	20	25	30
Current (mA)	19.5	22	24	28.5	37	45.5	49.7	54	63	67	Open Ckt Voltage (V)	19.5	19.5	19.5	19.5
Response Time (ms) ≤	4800	3800	2500	1600	850	650	450	400	250	250	Time (msec) ≤	5000	4000	2500	2000

5/2 INTERNAL PILOT OPERATED, SINGLE/ DOUBLE SOLENOID, SUBBASE MOUNTED VALVE

MARKING Explosion Proof

ENCLOSURE TYPE 37/ 39

SIZE	Power	BIS & PESO, DGMS	EAC - CuTR (Russia)	ATEX / INMETRO
I II IV	≤5W ≤8W ≤11W	Ex d IIC T6/T5 Gb, IP67 -40°C ≤ Ta ≤ 65°C FOR T6 -40°C ≤ Ta ≤ 70°C FOR T5	1 Ex d IIC T6/ T5/ T4 Gb IP66 Ex tb IIIC T80°C / T95°C / T130°C Db IP66 ИЛИ -40°C ≤ Ta ≤ 35°C FOR T6 -40°C ≤ Ta ≤ 50°C FOR T5 -40°C ≤ Ta ≤ 60°C FOR T4	Ex II 2G Ex d IIC T6/ T5/ T4 Gb IP66 Ex II 2D Ex tb IIIC T80°C / T95°C / T130°C Db IP66 -40°C ≤ Ta ≤ 35°C FOR T6 -40°C ≤ Ta ≤ 50°C FOR T5 -40°C ≤ Ta ≤ 60°C FOR T4 (Power ≤ 20W)
I II III	≤8W ≤13W ≤8W	Ex d IIC T6/T5 Gb, IP67 -40°C ≤ Ta ≤ 60°C FOR T6 -40°C ≤ Ta ≤ 70°C FOR T5		
III	≤15W	Ex d IIC T6/T5/T4 ≤Gb, IP67 -40°C ≤ Ta ≤ 50°C FOR T6 -40°C ≤ Ta ≤ 65°C FOR T5 -40°C ≤ Ta ≤ 70°C FOR T4		
III IV	≤5W ≤5W	Ex d IIC T6 Gb, IP67 -40°C ≤ Ta ≤ 70°C FOR T6		
II	≤20W	Ex d IIC T6/T5 Gb, IP67 -40°C ≤ Ta ≤ 55°C FOR T6 -40°C ≤ Ta ≤ 70°C FOR T5		
II	≤30W	Ex d IIC T6/T5/T4 Gb, IP67 -40°C ≤ Ta ≤ 40°C FOR T6 -40°C ≤ Ta ≤ 55°C FOR T5 -40°C ≤ Ta ≤ 70°C FOR T4		

ENCLOSURE TYPE 87

SIZE	Power	ATEX, IEC Ex, BIS & PESO, DGMS	INMETRO	EAC - CuTR (Russia) / UKRANE	KOSHA
III II IV	≤5W ≤8W ≤11W	Ex db IIC T6/T5/T4 Gb IP67 Ex tb IIIC T80°C/T95°C/T130°C Db IP67 -60°C ≤ Ta ≤ +65°C for T6 -60°C ≤ Ta ≤ +80°C for T5 -60°C ≤ Ta ≤ +100°C for T4	Ex db IIC T6/T5/T4 Gb Ex tb IIIC T85°C/T100°C/T135°C Db IP67 -60°C ≤ Ta ≤ +65°C for T6 -60°C ≤ Ta ≤ +80°C for T5 -60°C ≤ Ta ≤ +100°C for T4	1 Ex db IIC T6/T5/T4 Gb IP67 Ex tb IIIC T80°C/T95°C/T130°C Db ИЛИ -60°C ≤ Ta ≤ +65°C for T6 -60°C ≤ Ta ≤ +80°C for T5 -60°C ≤ Ta ≤ +100°C for T4	형식 또는 모델명 : 87, BCE 규격 또는 등급 : Ex d IIC T3-T6 제조사명 : Rotex Automation Limited 안전인증 번호 : 15-AV4BO-0000
III II	≤8W ≤13W	Ex db IIC T6/T5/T4 Gb IP67 Ex tb IIIC T80°C/T95°C/T130°C Db IP67 -60°C ≤ Ta ≤ +60°C for T6 -60°C ≤ Ta ≤ +75°C for T5 -60°C ≤ Ta ≤ +100°C for T4	Ex db IIC T6/T5/T4 Gb Ex tb IIIC T85°C/T100°C/T135°C Db IP67 -60°C ≤ Ta ≤ +60°C for T6 -60°C ≤ Ta ≤ +75°C for T5 -60°C ≤ Ta ≤ +100°C for T4	1 Ex db IIC T6/T5/T4 Gb IP67 Ex tb IIIC T80°C/T95°C/T130°C Db ИЛИ -60°C ≤ Ta ≤ +60°C for T6 -60°C ≤ Ta ≤ +75°C for T5 -60°C ≤ Ta ≤ +100°C for T4	
III	≤15W	Ex db IIC T6/T5/T4 Gb IP67 Ex tb IIIC T80°C/T95°C/T130°C Db IP67 -60°C ≤ Ta ≤ +50°C for T6 -60°C ≤ Ta ≤ +65°C for T5 -60°C ≤ Ta ≤ +100°C for T4	Ex db IIC T6/T5/T4 Gb Ex tb IIIC T85°C/T100°C/T135°C Db IP67 -60°C ≤ Ta ≤ +50°C for T6 -60°C ≤ Ta ≤ +65°C for T5 -60°C ≤ Ta ≤ +100°C for T4	1 Ex db IIC T6/T5/T4 Gb IP67 Ex tb IIIC T80°C/T95°C/T130°C Db ИЛИ -60°C ≤ Ta ≤ +50°C for T6 -60°C ≤ Ta ≤ +65°C for T5 -60°C ≤ Ta ≤ +100°C for T4	
IV	≤5W	Ex db IIC T6/T5/T4 Gb IP67 Ex tb IIIC T80°C/T95°C/T130°C Db IP67 -60°C ≤ Ta ≤ +70°C for T6 -60°C ≤ Ta ≤ +85°C for T5 -60°C ≤ Ta ≤ +100°C for T4	Ex db IIC T6/T5/T4 Gb Ex tb IIIC T85°C/T100°C/T135°C Db IP67 -60°C ≤ Ta ≤ +70°C for T6 -60°C ≤ Ta ≤ +85°C for T5 -60°C ≤ Ta ≤ +100°C for T4	1 Ex db IIC T6/T5/T4 Gb IP67 Ex tb IIIC T80°C/T95°C/T130°C Db ИЛИ -60°C ≤ Ta ≤ +70°C for T6 -60°C ≤ Ta ≤ +85°C for T5 -60°C ≤ Ta ≤ +100°C for T4	
II	≤20W	Ex db IIC T5/T4/T3 Gb IP67 Ex tb IIIC T95°C/T130°C/T155°C Db IP67 -60°C ≤ Ta ≤ +45°C for T5 -60°C ≤ Ta ≤ +80°C for T4 -60°C ≤ Ta ≤ +100°C for T3	Ex db IIC T5/T4/T3 Gb Ex tb IIIC T100°C/T135°C/T155°C Db IP67 -60°C ≤ Ta ≤ +45°C for T5 -60°C ≤ Ta ≤ +80°C for T4 -60°C ≤ Ta ≤ +100°C for T3	1 Ex db IIC T5/T4/T3 Gb IP67 Ex tb IIIC T95°C/T130°C/T155°C Db ИЛИ -60°C ≤ Ta ≤ +45°C for T5 -60°C ≤ Ta ≤ +80°C for T4 -60°C ≤ Ta ≤ +100°C for T3	
II	≤30W	Ex db IIC T4/T3 Gb IP67 Ex tb IIIC T130°C/T155°C Db IP67 -60°C ≤ Ta ≤ +60°C for T4 -60°C ≤ Ta ≤ +70°C for T3	Ex db IIC T4/T3 Gb Ex tb IIIC T135°C/T155°C Db IP67 -60°C ≤ Ta ≤ +60°C for T4 -60°C ≤ Ta ≤ +70°C for T3	1 Ex db IIC T4/T3 Gb IP67 Ex tb IIIC T130°C/T155°C Db ИЛИ -60°C ≤ Ta ≤ +60°C for T4 -60°C ≤ Ta ≤ +70°C for T3	

5/2 INTERNAL PILOT OPERATED, SINGLE/ DOUBLE SOLENOID, SUBBASE MOUNTED VALVE

MARKING Explosion Proof

ENCLOSURE TYPE 58

SIZE	Power	CE-ATEX, Insulation H
I II IV	≤5W ≤8W ≤11W	Ex II 2GD Ex e mb IIC T6/ T5 IP67 Ex tb IIIC T6/ T5 IP67 -40° C ≤ Ta ≤ 65° C for T6 -40° C ≤ Ta ≤ 70° C for T5
I II III	≤8W ≤13W ≤8W	Ex II 2GD Ex e mb IIC T6/ T5 IP67 Ex tb IIIC T6/ T5 IP67 -40° C ≤ Ta ≤ 60° C for T6 -40° C ≤ Ta ≤ 70° C for T5
III	≤15W	Ex II 2GD Ex e mb IIC T6/ T5/ T4 IP67 Ex tb IIIC T6/ T5/ T4 IP67 -40° C ≤ Ta ≤ 50° C for T6 -40° C ≤ Ta ≤ 65° C for T5 -40° C ≤ Ta ≤ 70° C for T4
III IV	≤5W ≤5W	Ex II 2GD Ex e mb IIC T6 IP67 Ex tb IIIC T6 IP67 -40° C ≤ Ta ≤ 70° C for T6
II	≤20W	Ex II 2GD Ex e mb IIC T6/ T5 IP67 Ex tb IIIC T6/ T5 IP67 -40° C ≤ Ta ≤ 55° C for T6 -40° C ≤ Ta ≤ 70° C for T5
II	≤30W	Ex II 2GD Ex e mb IIC T6/ T5/ T4 IP67 Ex tb IIIC T6/ T5/ T4 IP67 -40° C ≤ Ta ≤ 40° C for T6 -40° C ≤ Ta ≤ 55° C for T5 -40° C ≤ Ta ≤ 70° C for T4

ENCLOSURE TYPE 58LT

SIZE	Power	CE-ATEX, Insulation H
I II IV	≤5W ≤8W ≤11W	Ex II 2GD Ex e mb IIC T6/ T5 IP67 Ex tb IIIC T6/ T5 IP67 -60° C ≤ Ta ≤ 65° C for T6 -60° C ≤ Ta ≤ 70° C for T5
I II III	≤8W ≤13W ≤8W	Ex II 2GD Ex e mb IIC T6/ T5 IP67 Ex tb IIIC T6/ T5 IP67 -60° C ≤ Ta ≤ 60° C for T6 -60° C ≤ Ta ≤ 70° C for T5
III	≤15W	Ex II 2GD Ex e mb IIC T6/ T5/ T4 IP67 Ex tb IIIC T6/ T5/ T4 IP67 -60° C ≤ Ta ≤ 50° C for T6 -60° C ≤ Ta ≤ 65° C for T5 -60° C ≤ Ta ≤ 70° C for T4
III IV	≤5W ≤5W	Ex II 2GD Ex e mb IIC T6 IP67 Ex tb IIIC T6 IP67 -60° C ≤ Ta ≤ 70° C for T6
II	≤20W	Ex II 2GD Ex e mb IIC T6/ T5 IP67 Ex tb IIIC T6/ T5 IP67 -60° C ≤ Ta ≤ 55° C for T6 -60° C ≤ Ta ≤ 70° C for T5
II	≤30W	Ex II 2GD Ex e mb IIC T6/ T5/ T4 IP67 Ex tb IIIC T6/ T5/ T4 IP67 -60° C ≤ Ta ≤ 40° C for T6 -60° C ≤ Ta ≤ 55° C for T5 -60° C ≤ Ta ≤ 70° C for T4

ENCLOSURE TYPE 66, 67 & 71

Enclosure	ATEX/ IECEx (Eurpoe)/ INMETRO/ CEPTEL (Brazil)	EAC - CuTR (Russia)	BIS & PESO, DGMS
Al Cast	Ex ia IIC T5 Ga (-60°C≤Ta≤+75°C) Ex ia IIC T6 Ga (-60°C≤Ta≤+60°C) Ex ia IIIC T2oo 125°C IP67 Da (-60°C≤Ta≤+75°C)	0 Ex ia IIC T5 Ga IP67 (-60°C≤Ta≤+75°C) 0 Ex ia IIC T6 Ga IP67 (-60°C≤Ta≤+60°C) 0 Ex ia IIIC T2oo 125°C IP67 Da (-60°C≤Ta≤+75°C)	Ex ia I/IIC T5, IP67 (-40°C≤Ta≤75°C) Ex ia I/IIC T6, IP67 (-40°C≤Ta≤60°C)
SS Cast	Ex ia IIC T5 Ga (-60°C≤Ta≤+75°C) Ex ia IIC T6 Ga (-60°C≤Ta≤+60°C) Ex ia IIIC T2oo 125°C IP67 Da (-60°C≤Ta≤+75°C) Ex ia I Ma (-60°C≤Ta≤+75°C)	0 Ex ia IIC T5 Ga IP67 (-60°C≤Ta≤+75°C) 0 Ex ia IIC T6 Ga IP67 (-60°C≤Ta≤+60°C) 0 Ex ia IIIC T2oo 125°C IP67 Da (-60°C≤Ta≤+75°C) PO Ex ia I Ma (-60°C≤Ta≤+75°C) (ТОЛЬКО СТАЛЬ) ИЛИ	
Al Cast	Ukraine		
Al Cast	0 Ex ia IIC T5 X -60°C≤Ta≤+75°C 0 Ex ia IIC T6 X -60°C≤Ta≤+60°C		
SS Cast	PO Ia X -60°C≤Ta≤+75°C (ДЛЯ варіанта у сталюму корпусі) 0 Ex ia IIC T5 X -60°C≤Ta≤+75°C 0 Ex ia IIC T6 X -60°C≤Ta≤+60°C		

ENCLOSURE TYPE 65CR

BIS & PESO, DGMS
Ex ia I/IIC T5, IP67 (-40°C≤Ta≤75°C) Ex ia I/IIC T6, IP67 (-40°C≤Ta≤60°C)

MARKING Weather Proof

ENCLOSURE TYPE 17

US & Canada (UL Recognised)
TYPE 3, 3R, 3S, 4, 4X, 6 & 6P -60°C to +100°C POWER ≤20W -60°C to +60°C 20W< POWER ≤30W

5/2 INTERNAL PILOT OPERATED, SINGLE/ DOUBLE SOLENOID, SUBBASE MOUNTED VALVE

⑭ ACCESSORIES		
	CODE	DESCRIPTION
	① ✖	NIL
	A1	NRV Metallic Dust cap SS316, ideally suited for Protecting Valve internals from external Environment (Ambient Temperature - 60 °C to 150 °C), Water, Snow, Bugs, etc.
	A3	Silencer Sintered Bronze
	A4	Silencer Sintered SS
	A5	Dust Cap (Ambient Temperature - 20 °C to 80 °C)
	A6	NRV Dust cap Nylon, ideally suited for preventing external Environmental Media/ Water/ Liquid entering in the valve. Supplied only for 1/4" BSP/ NPT (Ambient Temperature - 20 °C to 80 °C)
	① ✖	NIL
	AP5A to AP5E	Adopter Plate (Refer to page13)
	MF008	Manifold (Refer to page14)
	① ✖	NIL
	B1	Weather Proof Cable Gland M20X1.5(M) Brass
	B5	ATEX Approved Cable Gland (Plastic) M20X1.5(M) (Ambient Temperature - 20 °C to 80 °C)
	B6	ATEX Approved Cable Gland (BRASS) M20X1.5(M) (Ambient Temperature - 20 °C to 80 °C)
	B7	ATEX Approved Cable Gland (SS316) M20X1.5(M) (Ambient Temperature - 20 °C to 80 °C)
	B8	Weather Proof Cable gland M20X1.5(M) (Plastic)
	B3	Explosion Proof Double Compression Cable Gland (BRASS) 1/2" NPT(M) (Ambient Temperature - 20 °C to 80 °C), CCOE/ PESO Certified
	B4	Explosion Proof Double Compression Cable Gland (SS316) 1/2" NPT(M) (Ambient Temperature - 20 °C to 80 °C), CCOE/ PESO Certified

VALVE

PORT

SOLENOID

5/2 INTERNAL PILOT OPERATED, SINGLE/ DOUBLE SOLENOID, SUBBASE MOUNTED VALVE

DIMENSIONS All Dimensions are in mm

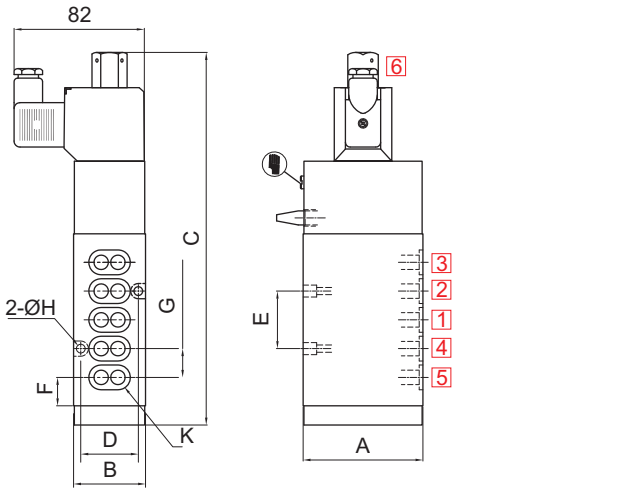

Valve Type	51445A, 51445, 51445V01, 51445AW, 51445LW, 51445V01LW
Enclosure Type	22
Enclosure Size	I
Body Material	AL, SS

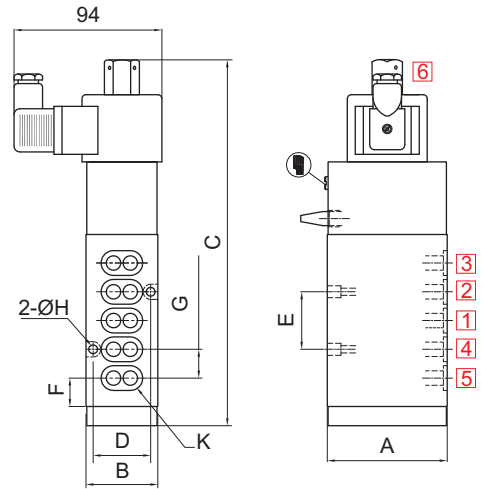

Valve Type	51445A, 51445, 51445V01, 51445AW, 51445LW, 51445V01LW, 51445A4, 51445L4, 51445V01L4, 51445IS, 51445V01IS, 51445AI, 51445IR, 51445AR, 51445V01IR
Enclosure Type	25, 65CR
Enclosure Size	III
Body Material	Al, SS

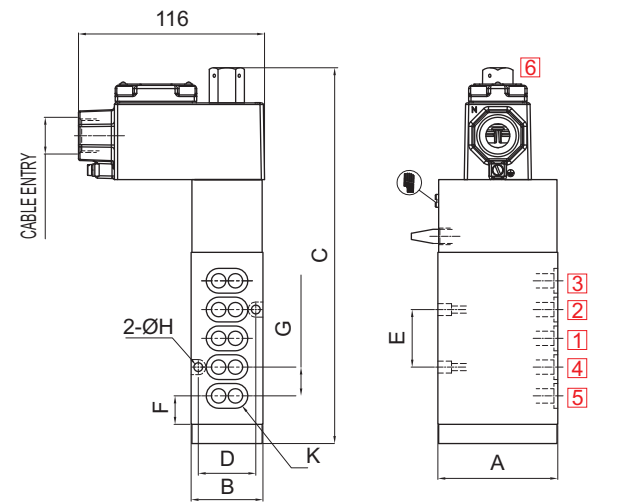

Valve Type	51445A, 51445, 51445V01, 51445AW, 51445LW, 51445V01LW
Enclosure Type	16, 19, 37, 39, 58, 58LT
Enclosure Size	I
Body Material	Al, SS

Valve Type : 51445A, 51445, 51445V01, 51445AW, 51445LW, 51445V01LW, 51445A4, 51445L4, 51445V01L4, 51445IS, 51445V01IS, 51445AI, 51445IR, 51445AR, 51445V01IR									
NW	K	A	B	C	D	E	F	G	H
6	SUBBASE	53	38	195	29	23	14	12	4.5
12	SUBBASE	75	45	233	36	36	18	18	6.5
25	SUBBASE	110	65	290	50	54	21	29	8.5

5/2 INTERNAL PILOT OPERATED, SINGLE/ DOUBLE SOLENOID, SUBBASE MOUNTED VALVE

DIMENSIONS

All Dimensions are in mm

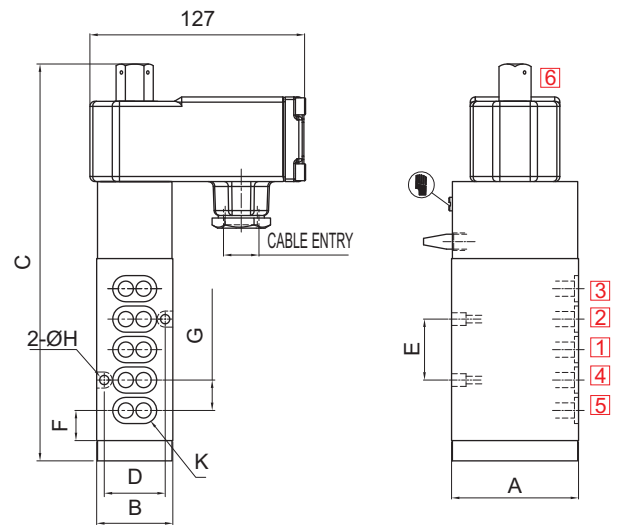
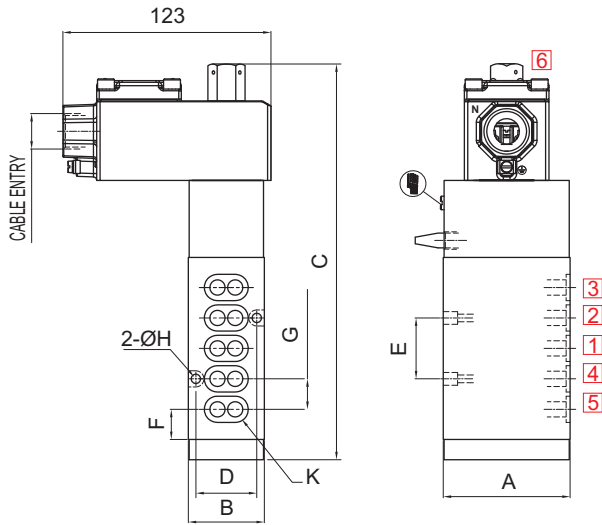

Valve Type	51445A, 51445, 51445V01, 51445AW, 51445LW, 51445V01LW, 51445A4, 51445L4, 51445V01L4, 51445IS, 51445V01IS, 51445AI, 51445IR, 51445AR, 51445V01IR
Enclosure Type	16, 19, 37, 39, 58, 58LT, 67
Enclosure Size	III
Body Material	AL, SS

Valve Type	51445A, 51445, 51445V01, 51445AW, 51445LW, 51445V01LW, 51445A4, 51445L4, 51445V01L4, 51445IS, 51445V01IS, 51445AI, 51445IR, 51445AR, 51445V01IR
Enclosure Type	17, 87, 66, 71
Enclosure Size	III
Body Material	AL, SS

Valve Type : 51445A, 51445, 51445V01, 51445AW, 51445LW, 51445V01LW, 51445A4, 51445L4, 51445V01L4, 51445IS, 51445V01IS, 51445AI, 51445IR, 51445AR, 51445V01IR									
NW	K	A	B	C	D	E	F	G	H
6	SUBBASE	53	38	195	29	23	14	12	4.5
12	SUBBASE	75	45	233	36	36	18	18	6.5
25	SUBBASE	110	65	290	50	54	21	29	8.5

5/2 INTERNAL PILOT OPERATED, SINGLE/ DOUBLE SOLENOID, SUBBASE MOUNTED VALVE

DIMENSIONS All Dimensions are in mm

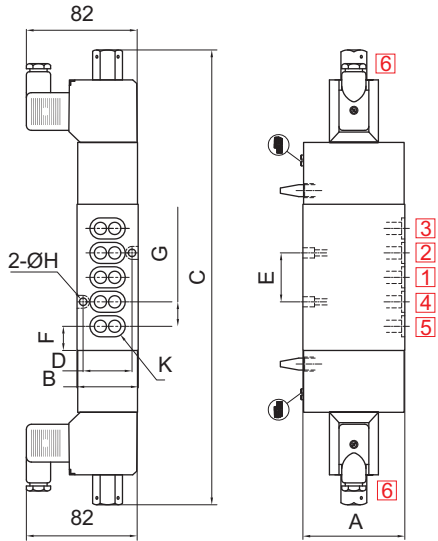

Valve Type	57445A, 57445, 57445V01, 57445LW, 57445AW, 57445V01LW
Enclosure Type	22
Enclosure Size	I
Body Material	AL, SS

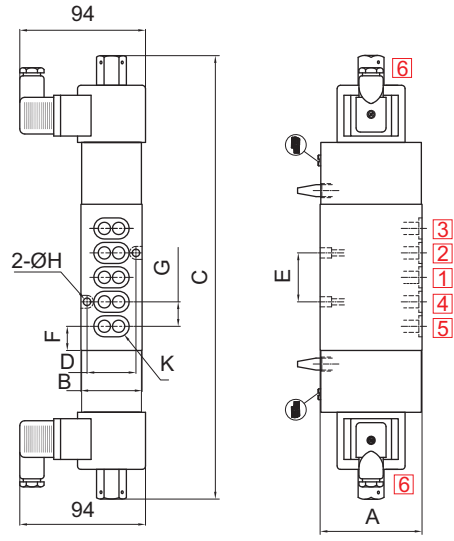

Valve Type	57445A, 57445, 57445V01, 57445AW, 57445LW, 57445V01LW, 57445A4, 57445L4, 57445V01L4, 57445IS, 57445AI, 57445V01IS, 57445IR, 57445AR, 57445V01IR
Enclosure Type	25, 65CR
Enclosure Size	III
Body Material	AL, SS

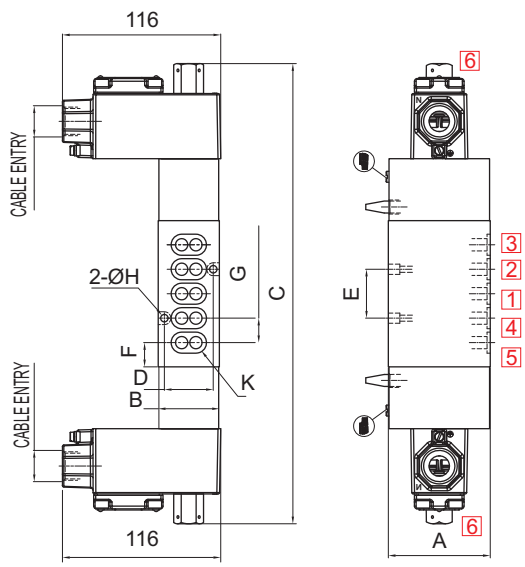

Valve Type	57445A, 57445, 57445V01, 57445LW, 57445AW, 57445V01LW
Enclosure Type	16, 19, 37, 39, 58, 58LT
Enclosure Size	I
Body Material	AL, SS

Valve Type : 57445A, 57445, 57445V01, 57445AW, 57445LW, 57445V01LW, 57445A4, 57445L4, 57445V01L4, 57445IS, 57445AI, 57445V01IS, 57445IR, 57445AR, 57445V01IR									
NW	K	A	B	C	D	E	F	G	H
6	SUBBASE	53	38	295	29	23	14	12	4.5
12	SUBBASE	75	45	335	36	36	18	18	6.5
25	SUBBASE	110	65	390	50	54	21	29	8.5

5/2 INTERNAL PILOT OPERATED, SINGLE/ DOUBLE SOLENOID, SUBBASE MOUNTED VALVE

DIMENSIONS

All Dimensions are in mm

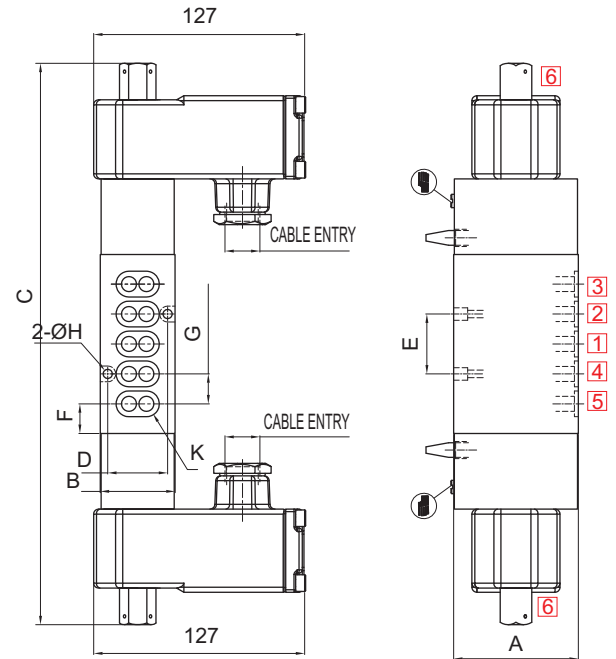
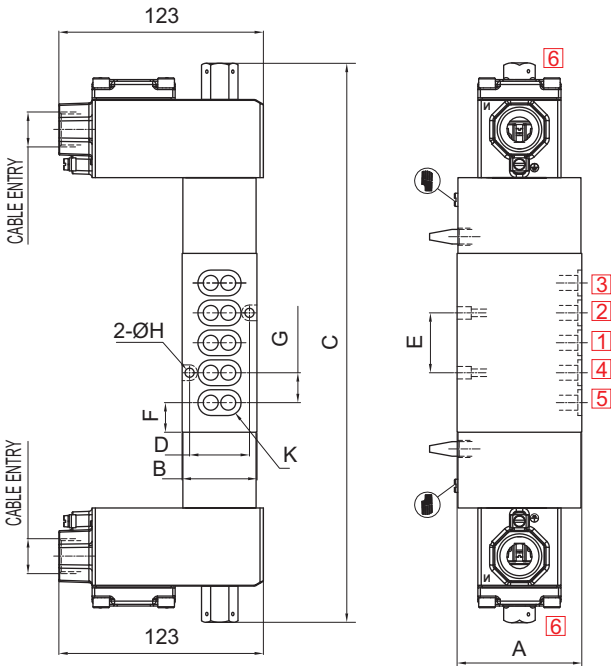

Valve Type	57445A, 57445, 57445V01, 57445AW, 57445LW, 57445V01LW, 57445A4, 57445L4, 57445V01L4, 57445IS, 57445AI, 57445V01IS, 57445IR, 57445AR, 57445V01IR
Enclosure Type	16, 19, 37, 39, 58, 58LT, 67
Enclosure Size	III
Body Material	AL, SS

Valve Type	57445A, 57445, 57445V01, 57445AW, 57445LW, 57445V01LW, 57445A4, 57445L4, 57445V01L4, 57445IS, 57445AI, 57445V01IS, 57445IR, 57445AR, 57445V01IR
Enclosure Type	17, 87, 66, 71
Enclosure Size	III
Body Material	AL, SS

Valve Type : 57445A, 57445, 57445V01, 57445AW, 57445LW, 57445V01LW, 57445A4, 57445L4, 57445V01L4, 57445IS, 57445AI, 57445V01IS, 57445IR, 57445AR, 57445V01IR									
NW	K	A	B	C	D	E	F	G	H
6	SUBBASE	53	38	295	29	23	14	12	4.5
12	SUBBASE	75	45	335	36	36	18	18	6.5
25	SUBBASE	110	65	390	50	54	21	29	8.5

5/2 INTERNAL PILOT OPERATED, SINGLE/ DOUBLE SOLENOID, SUBBASE MOUNTED VALVE

DIMENSIONS All Dimensions are in mm

ADOPTER PLATE-AP5A

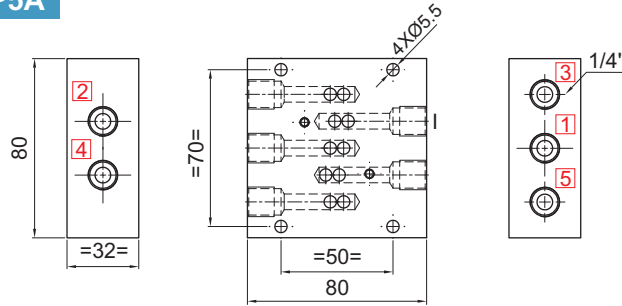

ADOPTER PLATE-AP5D/ AP5B

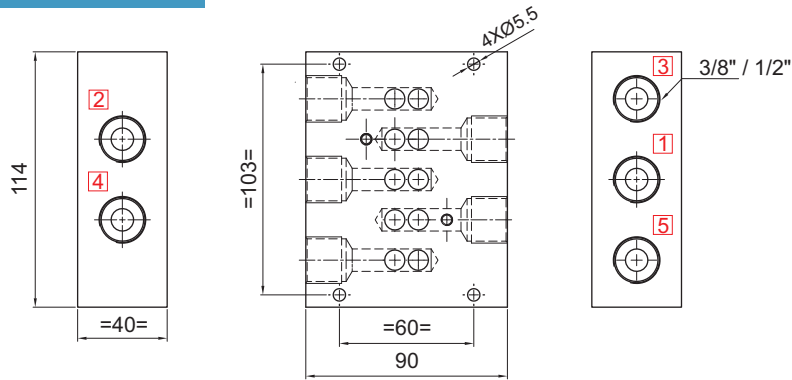

ADOPTER PLATE-AP5C/ AP5E

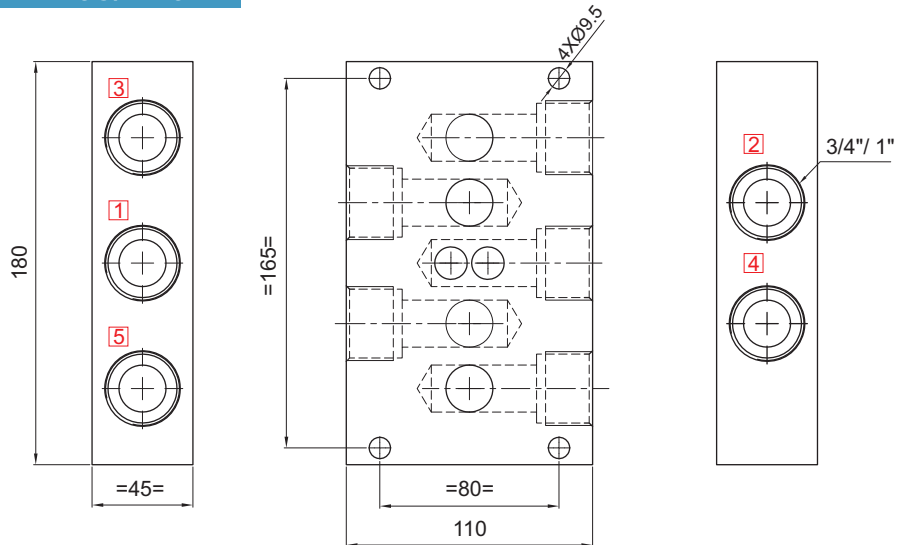

CODE	BSP	DESCRIPTION
AP5A	1/4" BSP	51445/ 57445
AP5D	3/8" BSP	51445/ 57445
AP5B	1/2" BSP	51445/ 57445
AP5E	3/4" BSP	51445/ 57445
AP5C	1" BSP	51445/ 57445

CODE	NPT	DESCRIPTION
AP5F	1/4" NPT	51445/ 57445
AP5G	3/8" NPT	51445/ 57445
AP5H	1/2" NPT	51445/ 57445
AP5J	3/4" NPT	51445/ 57445
AP5K	1" NPT	51445/ 57445

5/2 INTERNAL PILOT OPERATED, SINGLE/ DOUBLE SOLENOID, SUBBASE MOUNTED VALVE

DIMENSIONS All Dimensions are in mm

MANIFOLD

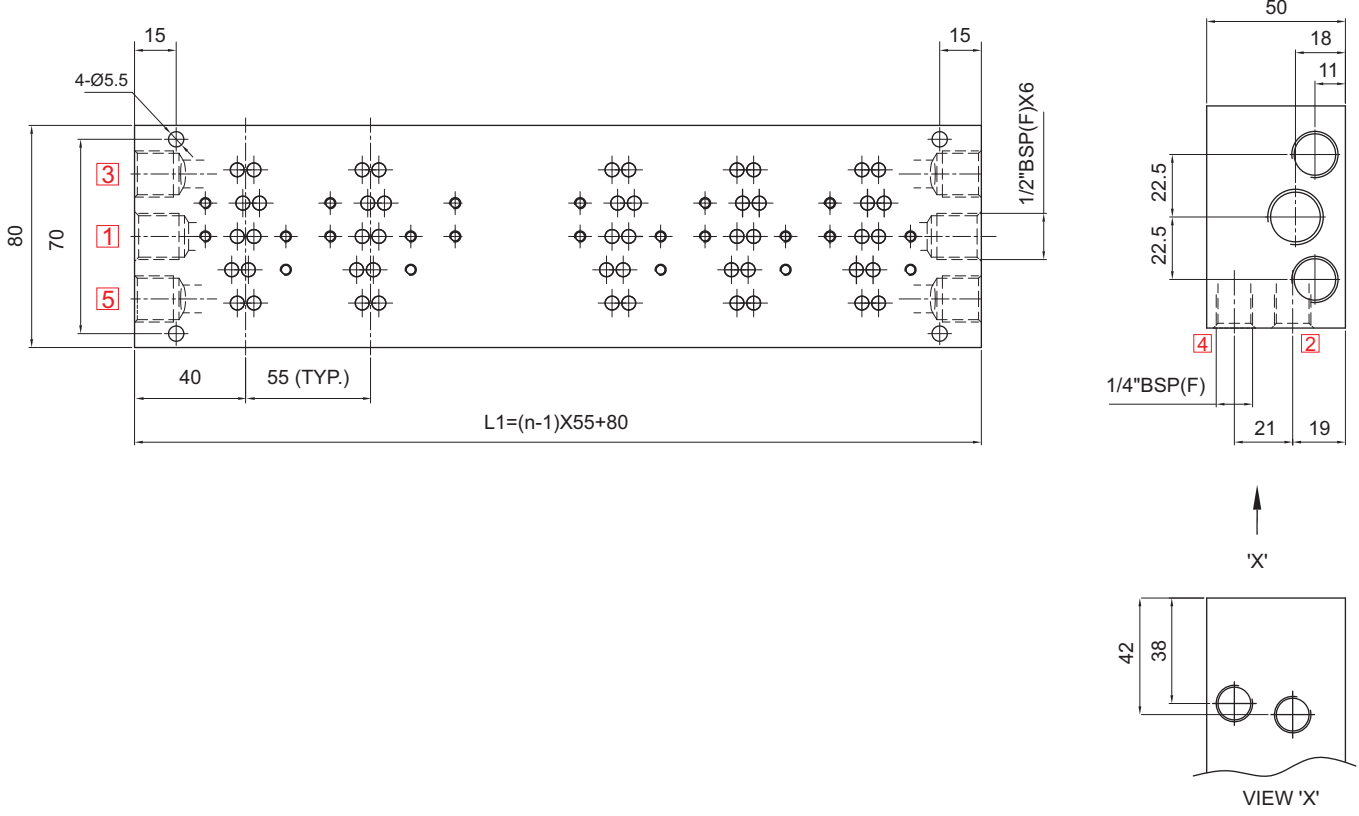

CODE	ORIFICE	VALVE TYPE	MAX. NO. OF VALVES/ MANIFOLD
MF008	6	51445, 57445	14



ROTEX AUTOMATION LIMITED

SALES HQ

B/703/704, Western Edge-II,
Off Western Express Highway,
Borivali (East), Mumbai-400066
Ph: +91 22 42111444
Fax: +91 22 42111400

OVERSEAS:

Bier Straat 117
3011 XA
Rotterdam
The Netherlands
Phone : +31 88 505 35 05
Email : info@rotexcontrols.nl

WORKS

UNIT 1

987/11, GIDC Makarpura,
Vadodara - 390010, Gujarat, INDIA.
Ph. : +91 265 2638136/ 2638795/ 46
Fax : +91 265 2638130

UNIT 2

C - 1 B/ 1501, 4 & 5, GIDC
Vithal Udyognagar - 388121,
Gujarat, INDIA.
Ph. : +91 2692 236224/ 236292/ 236399
Fax : +91 2692 236442