

5/2, 3/2 CONVERTIBLE INLINE POPPET, SPRING RETURN, NAMUR SINGLE SOLENOID VALVE



HORIZONTAL CABLE ENTRY
ALUMINIUM CAST ENCLOSURE
WEATHER PROOF Type 16, 19
EXPLOSION PROOF Type 58, 58LT, 67



MULTI PIN CONNECTOR
STEEL ENCLOSURE
WEATHER PROOF Type 70

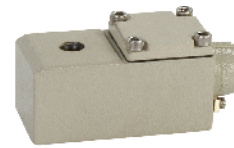

HORIZONTAL CABLE ENTRY
STAINLESS STEEL CAST ENCLOSURE
WEATHER PROOF Type 16-CO, 19-CO,
EXPLOSION PROOF Type 58-CO, 58LT-CO,
37-CO, 39-CO, 67-CO



DIN PLUG CONNECTOR
MOULDED ENCLOSURE
WEATHER PROOF Type 22



HORIZONTAL CABLE ENTRY
ALUMINIUM CAST ENCLOSURE
EXPLOSION PROOF Type 37, 39



DIN PLUG CONNECTOR
STEEL ENCLOSURE
WEATHER PROOF Type 25
EXPLOSION PROOF Type 65CR



BOTTOM CABLE ENTRY
ALUMINIUM CAST ENCLOSURE
WEATHER PROOF Type 17
EXPLOSION PROOF Type 87, 66, 71



BOTTOM CABLE ENTRY
STAINLESS STEEL CAST ENCLOSURE
WEATHER PROOF Type 17-CO
EXPLOSION PROOF Type 87-CO, 66-CO,
71-CO

**Interchangeable across
Voltage/ Current range without
affecting performance of the Valve**



Engineering For The Future

5/2, 3/2 CONVERTIBLE INLINE POPPET, SPRING RETURN, NAMUR SINGLE SOLENOID VALVE

FEATURES

- Bubble tight shut OFF
- Ideally suited where speed control by blocking exhaust is desired
- Power fail to reset
- Non return plug provided on the exhaust port
- In 3/2 mode exhaust purged to spring chamber
- Suitable for high speed cycling, speed upto 500 cycles/ min
- Life >20 million cycles

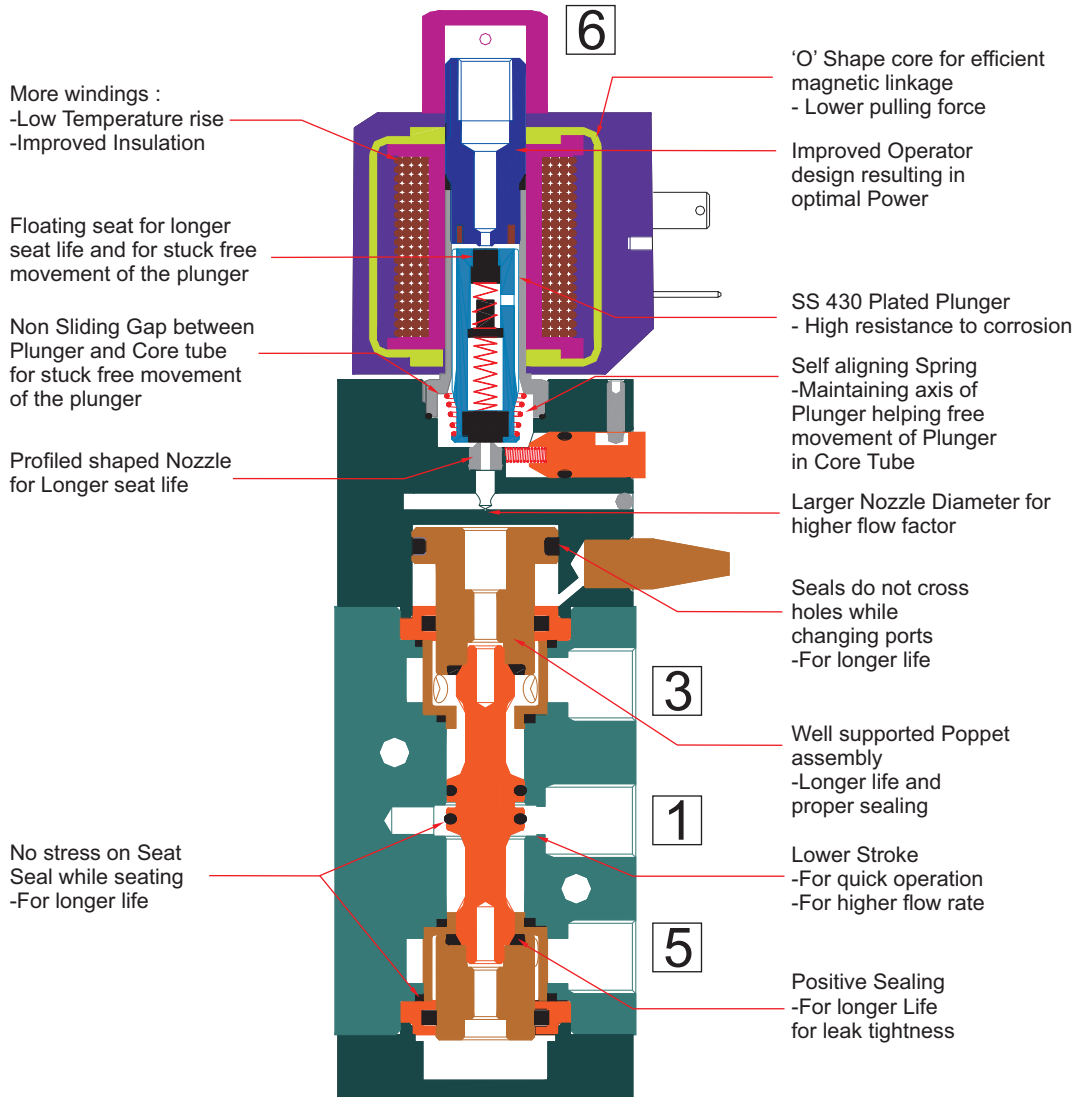

WEIGHT IN kg. (Appx.)

Valve

Orifice - Port Connection	Al	SS
6-2G/ 2R	0.90	1.90
12-4G/ 4R	1.70	3.90

Solenoid

Type	Size	Type	Size	Enclosure	
				Al	SS
25, 65CR	I	16, 19, 37,	I	0.55	1.20
	II	39, 58,	II, IV	0.85	1.70
	III	58LT, 67	III	0.60	1.50
	IV	17, 66, 71, 87	II, IV	1.00	1.65
			III	0.90	1.50

VOLTAGE VARIATION

(For Continuous Duty)

Rated Voltage	Operating Voltage
6	4.8V to 7.2V
12	9.6V to 14.4V
24	19.2V to 28.8V
48	38.4V to 57.6V
110 to 120	88V to 132V
220/ 230/ 240	176V to 264V
256	205V to 280V

SERIES : 52S

5/2, 3/2 CONVERTIBLE INLINE POPPET, SPRING RETURN, NAMUR SINGLE SOLENOID VALVE

TYPE	PRESSURE
51450	2 - 10 bar
51450LW	2 - 10 bar
51450L4	2 - 8 bar
51450IS	2 - 11 bar
51450IR	2 - 8 bar

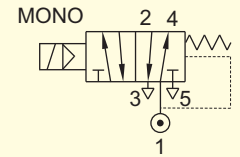

WETTED PARTS

Code	※	B5
Body	Anodized Aluminium	SS 316
Internals	Aluminium, Brass and SS 316	SS 316
Guide	SS 304	
Shadow-Ring	Copper	
Plunger, Insert	SS 430	
Spring	SS 302	
Fasteners	SS 304	
Seat, Seals	NBR, Viton	

Match Slot to 3/2 for 3/2



Match Slot to 5/2 for 5/2

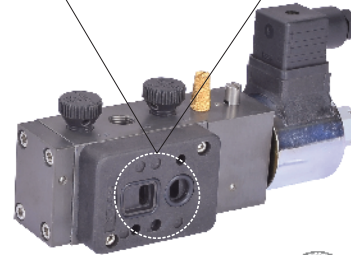

DGMS

PESO



CE

UL



EAC



KOSHA



NACE
MR 0175-1

APPLICATION

Operation of double/ single acting Actuator

SPARES

SPARE KIT	CODE
Seal Kit : Oring Set (Only for Intrinsically Safe Valve)	P98
Seal Kit : Oring Set and Plunger Assembly	98
Repair Kit : All Components except Body Cover and Solenoid	99
Repair Kit : All Components except Body and Solenoid (for Intrinsically Safe Valve)	99
Solenoid Kit : Solenoid, Gasket	34

POWER

Power	Normal		Low		Ex ia	
	6W/ 8W	2W	0.4W	Type : 66	Type : 65CR, 67, 71	
Type	51450	51450LW	51450LW 51450L4	51450	51450IS, 51450IR	
Size	I/ III	I/ III	III	III	III	

PORT CONNECTION

VALVE TYPE	MODE	INLET	OUTLET	OUTLET	EXHAUST	EXHAUST	PILOT EXHAUST
51450, 51450LW, 51450IS, 51450L4, 51450IR	Single Solenoid	1	2	4	3	5	6

Contact Rotex for

- Any other Temperature Range, Media and Application

5/2, 3/2 CONVERTIBLE INLINE POPPET, SPRING RETURN, NAMUR SINGLE SOLENOID VALVE

SPECIFICATION

VALVE		SOLENOID	
Valve Type	5/2, 3/2 Convertible Inline Poppet, Spring Return, NAMUR single Solenoid Valve	Voltage-Current	DC 12V, 24V, 48V, 110V, 220V, 256V
Body Material	Aluminium/ Stainless Steel 316		AC (50Hz/ 60Hz) 24V, 110V, 120V, 230V, 240V
Port Connection	1/4", 1/2"		AC/ DC (50Hz/ 60Hz/ DC) 24V, 110V, 120V, 220V, 240V
Orifice	6mm/ 12mm	Power	8W/ 6W/ 2W/ 0.4W
Seals	NBR/ Viton GLT	Protection	Weather Proof IP67 Explosion Proof Ex d, Ex ia, Ex e mb, IIC, T6/ T5/ T4 IP67
Manual Override	Stayput/ Momentary/ Without Manual Override	Cable Entry	Pg 9 / M20X1.5/ 1/2" NPT/ M25X1.5
Flow factor Orifice-kv/ Kv/ Cv	6mm-12/ 0.72/ 0.84 12mm-60/ 3.6/ 4.2		
Media	Air, Diesel, Hydraulic Oil, Inert Gas, Kerosene, LPG, Lubricating Oil, Petrol (Motor Spirit), Turbine Oil, Water		
⑬ Ambient, Fluid Temperature	- 25 °C to 75 °C, Optionally -40 °C to 140 °C		
Response ON/ OFF	≤ 50ms/ ≤ 90ms		
Pressure	2-8 bar, 2-10 bar, 2-11 bar		

ORDERING CODE Solenoid Valve (Valve Code + Solenoid Code)

VALVE TYPE	SIL	SUFFIX	ORIFICE	PORT CONNECTION	BODY INTERNAL	MANUAL OVERRIDE	SEAL	⑰ MEDIA	
51450V02	*	*	6	2G	B5	M0	S2G	*	
ACCESSORIES VALVE, PORT	+	SIZE	VOLTAGE, CURRENT	ENCLOSURE	⑦ MTL	SPECIAL	POWER	INSULATION	APPROVAL
A6		I	24V DC	16	CO	*	*	*	*
SIL	-	ACCESSORIES SOLENOID							
*		B4							

ORDERING CODE Valve Spare Kit

SPARE KIT	VALVE TYPE	SIL	SUFFIX	ORIFICE	PORT CONNECTION	BODY INTERNAL	MANUAL OVERRIDE
99	51450V02	*	*	6	2G	B5	M0
SEAL	ACCESSORIES VALVE, PORT						
S2G	A6						

ORDERING CODE Spare Solenoid

SOLENOID KIT	SIZE	VOLTAGE, CURRENT	ENCLOSURE	⑦ MTL	SPECIAL	POWER	INSULATION	APPROVAL
34	I	24V DC	16	CO	*	*	*	*
SIL	-	ACCESSORIES SOLENOID						
*		B4						

VALVE TYPE-ORIFICE	
CODE	DESCRIPTION
NORMAL POWER	
51450V02-6	2-10 bar, 8 Watt, Port 1/4"
51450-12	2-10 bar, 8 Watt, Port 1/2"
LOW POWER	
51450V02LW-6	2-10 bar, 2 Watt, Port 1/4", Power LW2
51450LW-12	2-10 bar, 2 Watt, Port 1/2", Power LW2
① 51450V02LW-6	2-10 bar, 0.4 Watt, Port 1/4", Size III, Power LB04
① 51450LW-12	2-10 bar, 0.4 Watt, Port 1/2", Size III, Power LB04
51450V02L4-6	2-8 bar, 0.4 Watt, Port 1/4", Size III, Power LW0.4
51450L4-12	2-8 bar, 0.4 Watt, Port 1/2", Size III, Power LW0.4
INTRINSICALLY SAFE Ex ia 24 V DC	
51450V02-6	2-10 bar, Port 1/4", Ex ia Enclosure Type 66, Size III
51450-12	2-10 bar, Port 1/2", Ex ia Enclosure Type 66, Size III
② 51450V02IS-6	2-11 bar, Port 1/4", Enclosure Type 65CR, 67, 71
② 51450IS-12	2-11 bar, Port 1/2", Enclosure Type 65CR, 67, 71
② 51450V02IR-6	2-8 bar, Port 1/4", Enclosure Type 65CR, 67, 71
② 51450IR-12	2-8 bar, Port 1/2", Enclosure Type 65CR, 67, 71

SIL CERTIFIED	
CODE	DESCRIPTION
① *	NO
SL	YES

SUFFIX	
CODE	DESCRIPTION
① *	NIL
⑧ AM	Ammonia

ORIFICE	
CODE	DESCRIPTION
6	6 mm
12	12 mm

PORT CONNECTION	
CODE	DESCRIPTION
2G	1/4" BSP
2R	1/4" NPT
4G	1/2" BSP
4R	1/2" NPT

BODY MATERIAL	
CODE	DESCRIPTION
① *	ALUMINIUM
B5	SS316
B5N	SS316 NACE Compliance

MANUAL OVERRIDE	
CODE	DESCRIPTION
M0	NIL
① *	Stayput
M8	Momentary

5/2, 3/2 CONVERTIBLE INLINE POPPET, SPRING RETURN, NAMUR SINGLE SOLENOID VALVE

SEAL		
CODE	GRADE, AMBIENT TEMPERATURE	MEDIA
① ✖	NBR, -25 °C to 75 °C	① ✖
S2G	VITON, -40 °C to 160 °C	✓

⑦ MEDIA	
CODE	DESCRIPTION
① ✖	Air

SIZE-VOLTAGE CURRENT		
CODE	SIZE	COIL VOLTAGE
I-12V DC	I	12V DC
I-24V DC	I	24V DC
I-24V 50Hz	I	24V 50Hz/ 60Hz
I-110V 50Hz	I	110V 50Hz/ 120V 60Hz
I-230V 50Hz	I	230V 50Hz/ 240V 60Hz
III-12V DC	III	12V DC
III-24V DC	III	24V DC
III-24V 50Hz	III	24V 50Hz/ 60Hz
III-24V AC/ DC	III	④ 24V 50Hz/ 60Hz/ DC
III-48V DC	III	48V DC
III-110V DC	III	110V DC
III-110V 50Hz	III	110V 50Hz/ 120V 60Hz
III-110V AC/ DC	III	④ 110V 50Hz/ 60Hz/ DC 120V 50Hz/ 60Hz/ DC
III-220V DC	III	220V DC
III-230V 50Hz	III	230V 50Hz/ 240V 60Hz
III-230V AC/ DC	III	④ 220V 50Hz/ 60Hz/ DC 240V 50Hz/ 60Hz/ DC
III-256V DC	III	256V DC

ENCLOSURE TYPE	
CODE	DESCRIPTION
WEATHER PROOF TERMINAL BOX	
⑤ 22	DIN Plug Solenoid, IP 67, Cable Entry Pg9, as per DIN43650B, Size I
⑤ 25	DIN Plug Solenoid, IP 67, Cable Entry Pg9, as per DIN43650A, Size III, IV
16	Integrated Terminal box, IP 67, 1/2" NPT, -40 °C to 100 °C
19	Integrated Terminal box, IP 67, M20X1.5, -40 °C to 100 °C
17	Integrated Terminal Box, IP67, Bottom Cable Entry, M25X1.5, Size III, IV
17-MS	Integrated Terminal Box, IP67, Bottom Cable Entry, M20X1.5, Size III, IV
17-NS	Integrated Terminal Box, IP67, Bottom Cable Entry, 1/2" NPT, Size III, IV
17-A	Integrated Terminal Box, IP68, Bottom Cable Entry, M25X1.5, Size III, IV
17-MS-A	Integrated Terminal Box, IP68, Bottom Cable Entry, M20X1.5, Size III, IV
17-NS-A	Integrated Terminal Box, IP68, Bottom Cable Entry, 1/2" NPT, Size III, IV
EXPLOSION PROOF Ex d (For Gas & Dust)	
⑮ 37	Ex d IIC IP66, -40 °C TO 60 °C, 1/2" NPT
⑮ 39	Ex d IIC IP66, -40 °C TO 60 °C, M20 X 1.5
87	Ex d IIC IP67, -60 °C TO 100 °C, M25 X 1.5, Size III, IV
87-MS	Ex d IIC IP67, -60 °C TO 100 °C, M20 X 1.5, Size III, IV
87-NS	Ex d IIC IP67, -60 °C TO 100 °C, 1/2" NPT, Size III, IV
87-A	Ex d IIC IP68, -60 °C TO 100 °C, M25 X 1.5, Size III, IV
87-MS-A	Ex d IIC IP68, -60 °C TO 100 °C, M20 X 1.5, Size III, IV
87-NS-A	Ex d IIC IP68, -60 °C TO 100 °C, 1/2" NPT, Size III, IV
FLAMEPROOF Ex e mb (For Gas & Dust)	
58	Ex e mb IIC, IP67, -40 °C TO 70 °C, M25 X 1.5
58-MS	Ex e mb IIC, IP67, -40 °C TO 70 °C, M20 X 1.5
58-NS	Ex e mb IIC, IP67, -40 °C TO 70 °C, 1/2" NPT
58LT	Ex e mb IIC, IP67, -60 °C TO 70 °C, M25 X 1.5
58LT-MS	Ex e mb IIC, IP67, -60 °C TO 70 °C, M20 X 1.5
58LT-NS	Ex e mb IIC, IP67, -60 °C TO 70 °C, 1/2" NPT
INTRINSICALLY SAFE Ex ia (For Gas & Dust)	
62	Ex ia IIC, IP67, -60 °C TO 70 °C, M25 X 1.5, Size IV, Booster Circuit
62-MS	Ex ia IIC, IP67, -60 °C TO 70 °C, M20 X 1.5, Size IV, Booster Circuit
62-NS	Ex ia IIC, IP67, -60 °C TO 70 °C, 1/2" NPT, Size IV, Booster Circuit
③ 65CR	Ex ia IIC, IP67, -60 °C TO 70 °C, Pg9, Size III, DIN Plug In Enclosure
66	Ex ia IIC, IP67, -60 °C TO 70 °C, M25 X 1.5, Size III, Booster Circuit
66MS	Ex ia IIC, IP67, -60 °C TO 70 °C, M20 X 1.5, Size III, Booster Circuit
66NS	Ex ia IIC, IP67, -60 °C TO 70 °C, 1/2" NPT, Size III, Booster circuit
67	Ex ia IIC, IP67, -60 °C TO 70 °C, M25 X 1.5, Size III
67MS	Ex ia IIC, IP67, -60 °C TO 70 °C, M20 X 1.5, Size III
67NS	Ex ia IIC, IP67, -60 °C TO 70 °C, 1/2" NPT, Size III
71	Ex ia IIC, IP67, -60 °C TO 70 °C, M25 X 1.5, Size III
71MS	Ex ia IIC, IP67, -60 °C TO 70 °C, M20 X 1.5, Size III
71NS	Ex ia IIC, IP67, -60 °C TO 70 °C, 1/2" NPT, Size III

⑦ ENCLOSURE MATERIAL	
CODE	DESCRIPTION
① ✖	Aluminium Cast Epoxy Powder Coated
CO	CF8M (Stainless Steel Cast)

SPECIAL	
CODE	DESCRIPTION
① ✖	NIL
⑦ FR	Full Rectifier with Surge Suppressor Size III, IV
⑳ ㉑ LD	LED, Size III, IV
⑫ ㉒ SS	Surge Suppressor Size III, IV
⑳ RC	Half Rectifier with Surge Suppressor Size II, III

INSULATION	
CODE	DESCRIPTION
① ✖	CLASS F
H	CLASS H

SIL	
CODE	DESCRIPTION
① ✖	NO
SL	YES

POWER														
CODE	SIZE	POWER WATT	12V DC	24V DC	24V 50Hz	24V AC/ DC	48V DC	110V DC	110V 50Hz	110V AC/ DC	230V 50Hz	220V DC	230V AC/ DC	256V DC
			12V DC	24V DC	24V 50Hz/ 60 Hz	④ 24V 50Hz/ 60 Hz/ DC	48V DC	110V DC	110V 50Hz/ 120V 60Hz	④ 110V 50Hz/ 60Hz/ DC	④ 120V 50Hz/ 60Hz/ DC	230V 50Hz/ 240V 60Hz	220V DC	④ 220V 50Hz/ 60Hz/ DC
LW2	I	2.0		✓										
① ✖	I	6.0			✓				✓					
① ✖	I	8.0	✓	✓										
LW0.4	III	0.4		✓										
LW2	III	2.0	✓	✓				✓		✓				
① ✖	III	6.0			✓				✓					
① ✖	III	8.0	✓	✓		✓	✓	✓		✓		✓	✓	
		9.0								✓				✓
①														
LB04	III	0.4		✓										

5/2, 3/2 CONVERTIBLE INLINE POPPET, SPRING RETURN, NAMUR SINGLE SOLENOID VALVE

APPROVAL		ENCLOSURE TYPE												
CODE	DESCRIPTION	17	37	39	58	58LT	62	65CR	66	67	71	87	17A	87A
15 ✖	CCOE/ PESO + BIS, Insulation Class H		✓	✓			✓	✓	✓	✓	✓	✓		✓
01	CE - ATEX, Insulation Class H		✓	✓	✓	✓								
01	IEC Ex + ATEX, Insulation Class H						✓		✓	✓	✓	✓		✓
01B	INDIAN + ATEX, Insulation Class H		✓	✓			✓		✓			✓		✓
02	UL Recognised, for USA and Canada, Type 3, 3S, 4, 4X, 6, 6P UL file Number E 342217	✓											✓	
03	INMETRO + ATEX, Insulation Class H		✓	✓			✓		✓	✓	✓	✓		✓
03C	IEC Ex + ATEX + IN METRO + CuTR-EAC											✓		✓
04	CuTR- EAC + ATEX , Insulation Class H		✓	✓			✓		✓	✓	✓	✓		✓
21	07 KOSHA + ATEX, Insulation Class H											✓		✓
08	Ukraine, Insulation Class H						✓		✓	✓	✓	✓		✓
20	CE (Weatherproof Solenoid)	✓											✓	
30	EAC EAC MARK	✓											✓	

Note :

- ① Do not Specify when opted for
- ② Approval Other than BIS, CCOE/ PESO, DGMS
- ③ Approved BIS, CCOE/ PESO, DGMS
- ④ Opt FR from special
- ⑤ Current DC, 50Hz, 60Hz
- ⑦ Do not Opt for Enclosure Type 01, 06, 22, 25
- ⑧ Select Body Material SS316, (B5) Solenoid with DC or AC/ DC
- ⑨ All variation of 17, 37, 39, 58, 58LT, 65CR, 66, 67, 71, 87 included
- ⑩ Media should be Oil free Air/ Inert Gas/ Water
- ⑪ Do not opt for 01, 06, 22, 25. In Rush 2W for 100 msec, Holding 0.4W
- ⑫ Current DC
- ⑬ Ambient Temperature restricted for Enclosure Type 17, 37, 39, 58, 58LT, 62, 65CR, 66, 67, 71, 87 to Solenoid Ambient Temperature
- ⑭ Select Nil or one Accessories from each valve A1 to A6 for Solenoid and from B1 to B8
- ⑮ IP 67 Certified by BIS, CCOE/ PESO, DGMS
- ⑰ Can not be opted for Enclosure Type 01, 06
- ⑱ Can be opted for Enclosure Type 01, 06, 16, 19, 22, 25
- ⑲ KOSHA certificate only for enclosure size II ≤ 20W
- ⑳ Do not Opt for Enclosure Type 01, 06, 22
- ㉑ Media Code shall be part of Ordering Code other than Default Media Type
- ㉒ For Solenoid type 25 with AC current supply, Use 50Hz with Special RC Option
- ㉓ For Intrinsically Safe Solenoid, LD (LED) can be opted with CCOE/PESO certification only
- ㉔ Select Seal Kit Code P98 & Repair Kit Code 99 for Intrinsically Safe Valve

ENTITY PARAMETER

Entity Parameter	
Ui	32V DC
Ii	230mA
Pi	2.3W
Ci	0
Li	0

MINIMUM OPERATING PARAMETER

Type	66	66..LD..	65CR	67	67..LD..	71	71..LD..	65CR	67	67..LD..	71	71..LD..
Minimum Voltage (V)	10	10	11	11	11	11	11	14	14	15	14	14
Minimum Current (mA)	20	21	19	19	22	19	22	25	25	28	25	28
Minimum Power (W)	0.20	0.21	0.21	0.21	0.24	0.21	0.24	0.35	0.35	0.42	0.35	0.42
LED	No	Yes	No	No	Yes	No	Yes	No	No	Yes	No	Yes
Pressure (bar)	As per Solenoid Valve rating		Maximum 8.0					Maximum 11.0				

RESPONSE ON TIME FOR SOLENOID TYPE 66, 66..LD..

Voltage (V)	10	11	12	14	18	22	24	26	30	32	Current (mA)	18.5	20	25	30
Current (mA)	20	22	24	28.5	37	45.5	49.7	54	63	67	Open Ckt Voltage (V)	19.5	19.5	19.5	19.5
Response Time (ms) ≤	4800	3800	2500	1600	850	650	450	400	250	250	Time (ms) ≤	5000	4000	2500	2000

5/2, 3/2 CONVERTIBLE INLINE POPPET, SPRING RETURN, NAMUR SINGLE SOLENOID VALVE

MARKING Explosion Proof

ENCLOSURE TYPE 37/ 39

SIZE	Power	BIS & PESO, DGMS	EAC - CuTR (Russia)	ATEX / INMETRO
I II IV	≤5W ≤8W ≤11W	Ex d IIC T6/T5 Gb, IP67 -40°C ≤ Ta ≤ 65°C FOR T6 -40°C ≤ Ta ≤ 70°C FOR T5	1 Ex d IIC T6/ T5/ T4 Gb IP66 Ex tb IIIC T80°C / T95°C / T130°C Db IP66 ИЛИ -40°C ≤ Ta ≤ 35°C FOR T6 -40°C ≤ Ta ≤ 50°C FOR T5 -40°C ≤ Ta ≤ 60°C FOR T4	Ex II 2G Ex d IIC T6/ T5/ T4 Gb IP66 Ex II 2D Ex tb IIIC T80°C / T95°C / T130°C Db IP66 -40°C ≤ Ta ≤ 35°C FOR T6 -40°C ≤ Ta ≤ 50°C FOR T5 -40°C ≤ Ta ≤ 60°C FOR T4 (Power ≤ 20W)
I II III	≤8W ≤13W ≤8W	Ex d IIC T6/T5 Gb, IP67 -40°C ≤ Ta ≤ 60°C FOR T6 -40°C ≤ Ta ≤ 70°C FOR T5		
III	≤15W	Ex d IIC T6/T5/T4 ≤Gb, IP67 -40°C ≤ Ta ≤ 50°C FOR T6 -40°C ≤ Ta ≤ 65°C FOR T5 -40°C ≤ Ta ≤ 70°C FOR T4		
III IV	≤5W ≤5W	Ex d IIC T6 Gb, IP67 -40°C ≤ Ta ≤ 70°C FOR T6		
II	≤20W	Ex d IIC T6/T5 Gb, IP67 -40°C ≤ Ta ≤ 55°C FOR T6 -40°C ≤ Ta ≤ 70°C FOR T5		
II	≤30W	Ex d IIC T6/T5/T4 Gb, IP67 -40°C ≤ Ta ≤ 40°C FOR T6 -40°C ≤ Ta ≤ 55°C FOR T5 -40°C ≤ Ta ≤ 70°C FOR T4		

ENCLOSURE TYPE 87

SIZE	Power	ATEX, IEC Ex, BIS & PESO, DGMS	INMETRO	EAC - CuTR (Russia) / UKRANE	KOSHA
III II IV	≤5W ≤8W ≤11W	Ex db IIC T6/T5/T4 Gb IP67 Ex tb IIIC T80°C/T95°C/T130°C Db IP67 -60°C ≤ Ta ≤ +65°C for T6 -60°C ≤ Ta ≤ +80°C for T5 -60°C ≤ Ta ≤ +100°C for T4	Ex db IIC T6/T5/T4 Gb Ex tb IIIC T85°C/T100°C/T135°C Db IP67 -60°C ≤ Ta ≤ +65°C for T6 -60°C ≤ Ta ≤ +80°C for T5 -60°C ≤ Ta ≤ +100°C for T4	1 Ex db IIC T6/T5/T4 Gb IP67 Ex tb IIIC T80°C/T95°C/T130°C Db ИЛИ -60°C ≤ Ta ≤ +65°C for T6 -60°C ≤ Ta ≤ +80°C for T5 -60°C ≤ Ta ≤ +100°C for T4	형식 또는 모델명 : 87, BCE 규격 또는 등급 : Ex d IIC T3-T6 제조사명 : Rotex Automation Limited 안전인증 번호 : 15-AV4BO-0000
III II	≤8W ≤13W	Ex db IIC T6/T5/T4 Gb IP67 Ex tb IIIC T80°C/T95°C/T130°C Db IP67 -60°C ≤ Ta ≤ +60°C for T6 -60°C ≤ Ta ≤ +75°C for T5 -60°C ≤ Ta ≤ +100°C for T4	Ex db IIC T6/T5/T4 Gb Ex tb IIIC T85°C/T100°C/T135°C Db IP67 -60°C ≤ Ta ≤ +60°C for T6 -60°C ≤ Ta ≤ +75°C for T5 -60°C ≤ Ta ≤ +100°C for T4	1 Ex db IIC T6/T5/T4 Gb IP67 Ex tb IIIC T80°C/T95°C/T130°C Db ИЛИ -60°C ≤ Ta ≤ +60°C for T6 -60°C ≤ Ta ≤ +75°C for T5 -60°C ≤ Ta ≤ +100°C for T4	
III	≤15W	Ex db IIC T6/T5/T4 Gb IP67 Ex tb IIIC T80°C/T95°C/T130°C Db IP67 -60°C ≤ Ta ≤ +50°C for T6 -60°C ≤ Ta ≤ +65°C for T5 -60°C ≤ Ta ≤ +100°C for T4	Ex db IIC T6/T5/T4 Gb Ex tb IIIC T85°C/T100°C/T135°C Db IP67 -60°C ≤ Ta ≤ +50°C for T6 -60°C ≤ Ta ≤ +65°C for T5 -60°C ≤ Ta ≤ +100°C for T4	1 Ex db IIC T6/T5/T4 Gb IP67 Ex tb IIIC T80°C/T95°C/T130°C Db ИЛИ -60°C ≤ Ta ≤ +50°C for T6 -60°C ≤ Ta ≤ +65°C for T5 -60°C ≤ Ta ≤ +100°C for T4	
IV	≤5W	Ex db IIC T6/T5/T4 Gb IP67 Ex tb IIIC T80°C/T95°C/T130°C Db IP67 -60°C ≤ Ta ≤ +70°C for T6 -60°C ≤ Ta ≤ +85°C for T5 -60°C ≤ Ta ≤ +100°C for T4	Ex db IIC T6/T5/T4 Gb Ex tb IIIC T85°C/T100°C/T135°C Db IP67 -60°C ≤ Ta ≤ +70°C for T6 -60°C ≤ Ta ≤ +85°C for T5 -60°C ≤ Ta ≤ +100°C for T4	1 Ex db IIC T6/T5/T4 Gb IP67 Ex tb IIIC T80°C/T95°C/T130°C Db ИЛИ -60°C ≤ Ta ≤ +70°C for T6 -60°C ≤ Ta ≤ +85°C for T5 -60°C ≤ Ta ≤ +100°C for T4	
II	≤20W	Ex db IIC T5/T4/T3 Gb IP67 Ex tb IIIC T95°C/T130°C/T155°C Db IP67 -60°C ≤ Ta ≤ +45°C for T5 -60°C ≤ Ta ≤ +80°C for T4 -60°C ≤ Ta ≤ +100°C for T3	Ex db IIC T5/T4/T3 Gb Ex tb IIIC T100°C/T135°C/T155°C Db IP67 -60°C ≤ Ta ≤ +45°C for T5 -60°C ≤ Ta ≤ +80°C for T4 -60°C ≤ Ta ≤ +100°C for T3	1 Ex db IIC T5/T4/T3 Gb IP67 Ex tb IIIC T95°C/T130°C/T155°C Db ИЛИ -60°C ≤ Ta ≤ +45°C for T5 -60°C ≤ Ta ≤ +80°C for T4 -60°C ≤ Ta ≤ +100°C for T3	
II	≤30W	Ex db IIC T4/T3 Gb IP67 Ex tb IIIC T130°C/T155°C Db IP67 -60°C ≤ Ta ≤ +60°C for T4 -60°C ≤ Ta ≤ +70°C for T3	Ex db IIC T4/T3 Gb Ex tb IIIC T135°C/T155°C Db IP67 -60°C ≤ Ta ≤ +60°C for T4 -60°C ≤ Ta ≤ +70°C for T3	1 Ex db IIC T4/T3 Gb IP67 Ex tb IIIC T130°C/T155°C Db ИЛИ -60°C ≤ Ta ≤ +60°C for T4 -60°C ≤ Ta ≤ +70°C for T3	

5/2, 3/2 CONVERTIBLE INLINE POPPET, SPRING RETURN, NAMUR SINGLE SOLENOID VALVE

MARKING Explosion Proof

ENCLOSURE TYPE 58

SIZE	Power	CE-ATEX, Insulation H
I II IV	≤5W ≤8W ≤11W	Ex II 2GD Ex e mb IIC T6/ T5 IP67 Ex tb IIIC T6/ T5 IP67 -40° C ≤ Ta ≤ 65° C for T6 -40° C ≤ Ta ≤ 70° C for T5
I II III	≤8W ≤13W ≤8W	Ex II 2GD Ex e mb IIC T6/ T5 IP67 Ex tb IIIC T6/ T5 IP67 -40° C ≤ Ta ≤ 60° C for T6 -40° C ≤ Ta ≤ 70° C for T5
III	≤15W	Ex II 2GD Ex e mb IIC T6/ T5/ T4 IP67 Ex tb IIIC T6/ T5/ T4 IP67 -40° C ≤ Ta ≤ 50° C for T6 -40° C ≤ Ta ≤ 65° C for T5 -40° C ≤ Ta ≤ 70° C for T4
III IV	≤5W ≤5W	Ex II 2GD Ex e mb IIC T6 IP67 Ex tb IIIC T6 IP67 -40° C ≤ Ta ≤ 70° C for T6
II	≤20W	Ex II 2GD Ex e mb IIC T6/ T5 IP67 Ex tb IIIC T6/ T5 IP67 -40° C ≤ Ta ≤ 55° C for T6 -40° C ≤ Ta ≤ 70° C for T5
II	≤30W	Ex II 2GD Ex e mb IIC T6/ T5/ T4 IP67 Ex tb IIIC T6/ T5/ T4 IP67 -40° C ≤ Ta ≤ 40° C for T6 -40° C ≤ Ta ≤ 55° C for T5 -40° C ≤ Ta ≤ 70° C for T4

ENCLOSURE TYPE 58LT

SIZE	Power	CE-ATEX, Insulation H
I II IV	≤5W ≤8W ≤11W	Ex II 2GD Ex e mb IIC T6/ T5 IP67 Ex tb IIIC T6/ T5 IP67 -60° C ≤ Ta ≤ 65° C for T6 -60° C ≤ Ta ≤ 70° C for T5
I II III	≤8W ≤13W ≤8W	Ex II 2GD Ex e mb IIC T6/ T5 IP67 Ex tb IIIC T6/ T5 IP67 -60° C ≤ Ta ≤ 60° C for T6 -60° C ≤ Ta ≤ 70° C for T5
III	≤15W	Ex II 2GD Ex e mb IIC T6/ T5/ T4 IP67 Ex tb IIIC T6/ T5/ T4 IP67 -60° C ≤ Ta ≤ 50° C for T6 -60° C ≤ Ta ≤ 65° C for T5 -60° C ≤ Ta ≤ 70° C for T4
III IV	≤5W ≤5W	Ex II 2GD Ex e mb IIC T6 IP67 Ex tb IIIC T6 IP67 -60° C ≤ Ta ≤ 70° C for T6
II	≤20W	Ex II 2GD Ex e mb IIC T6/ T5 IP67 Ex tb IIIC T6/ T5 IP67 -60° C ≤ Ta ≤ 55° C for T6 -60° C ≤ Ta ≤ 70° C for T5
II	≤30W	Ex II 2GD Ex e mb IIC T6/ T5/ T4 IP67 Ex tb IIIC T6/ T5/ T4 IP67 -60° C ≤ Ta ≤ 40° C for T6 -60° C ≤ Ta ≤ 55° C for T5 -60° C ≤ Ta ≤ 70° C for T4

ENCLOSURE TYPE 66, 67 & 71

Enclosure	ATEX/ IECEx (Eurpoe)/ INMETRO/ CEPTEL (Brazil)	EAC - CuTR (Russia)	BIS & PESO, DGMS
Al Cast	Ex ia IIC T5 Ga (-60°C≤Ta≤+75°C) Ex ia IIC T6 Ga (-60°C≤Ta≤+60°C) Ex ia IIIC T2oo 125°C IP67 Da (-60°C≤Ta≤+75°C)	0 Ex ia IIC T5 Ga IP67 (-60°C≤Ta≤+75°C) 0 Ex ia IIC T6 Ga IP67 (-60°C≤Ta≤+60°C) 0 Ex ia IIIC T2oo 125°C IP67 Da (-60°C≤Ta≤+75°C)	Ex ia I/IIIC T5, IP67 (-40°C≤Ta≤75°C) Ex ia I/IIIC T6, IP67 (-40°C≤Ta≤60°C)
SS Cast	Ex ia IIC T5 Ga (-60°C≤Ta≤+75°C) Ex ia IIC T6 Ga (-60°C≤Ta≤+60°C) Ex ia IIIC T2oo 125°C IP67 Da (-60°C≤Ta≤+75°C) Ex ia I Ma (-60°C≤Ta≤+75°C)	0 Ex ia IIC T5 Ga IP67 (-60°C≤Ta≤+75°C) 0 Ex ia IIC T6 Ga IP67 (-60°C≤Ta≤+60°C) 0 Ex ia IIIC T2oo 125°C IP67 Da (-60°C≤Ta≤+75°C) PO Ex ia I Ma (-60°C≤Ta≤+75°C) (ТОЛЬКО СТАЛЬ) ИЛИ	
Al Cast	Ukraine		
Al Cast	0 Ex ia IIC T5 X -60°C≤Ta≤+75°C 0 Ex ia IIC T6 X -60°C≤Ta≤+60°C		
SS Cast	PO Ia X -60°C≤Ta≤+75°C (ДЛЯ варіанта у сталюму корпусі) 0 Ex ia IIC T5 X -60°C≤Ta≤+75°C 0 Ex ia IIC T6 X -60°C≤Ta≤+60°C		

ENCLOSURE TYPE 65CR

BIS & PESO, DGMS
Ex ia I/IIIC T5, IP67 (-40°C≤Ta≤75°C) Ex ia I/IIIC T6, IP67 (-40°C≤Ta≤60°C)

MARKING Weather Proof

ENCLOSURE TYPE 17

US & Canada (UL Recognised)
TYPE 3, 3R, 3S, 4, 4X, 6 & 6P -60°C to +100°C POWER ≤20W -60°C to +60°C 20W< POWER ≤30W

5/2, 3/2 CONVERTIBLE INLINE POPPET, SPRING RETURN, NAMUR SINGLE SOLENOID VALVE

14 ACCESSORIES		
	CODE	DESCRIPTION
	① ✖	NIL
	A1	NRV Metallic Dust cap SS316, ideally suited for Protecting Valve internals from external Environment (Ambient Temperature - 60 °C to 150 °C), Water, Snow, Bugs, etc.
	A3	Silencer Sintered Bronze
	A4	Silencer Sintered SS
	A5	Dust Cap (Ambient Temperature - 20 °C to 80 °C)
	A6	NRV Dust cap Nylon, ideally suited for preventing external Environmental Media/ Water/ Liquid entering in the valve. Supplied only for 1/4" BSP/ NPT (Ambient Temperature - 20 °C to 80 °C)
	① ✖	NIL
	B1	Weather Proof Cable Gland M20X1.5(M) Brass
	B5	ATEX Approved Cable Gland (Plastic) M20X1.5(M) (Ambient Temperature - 20 °C to 80 °C)
	B6	ATEX Approved Cable Gland (BRASS) M20X1.5(M) (Ambient Temperature - 20 °C to 80 °C)
	B7	ATEX Approved Cable Gland (SS316) M20X1.5(M) (Ambient Temperature - 20 °C to 80 °C)
	B8	Weather Proof Cable gland M20X1.5(M) (Plastic)
	B3	Explosion Proof Double Compression Cable Gland (BRASS) 1/2" NPT(M) (Ambient Temperature - 20 °C to 80 °C), CCOE/ PESO Certified
	B4	Explosion Proof Double Compression Cable Gland (SS316) 1/2" NPT(M) (Ambient Temperature - 20 °C to 80 °C), CCOE/ PESO Certified

VALVE

SOLENOID

5/2, 3/2 CONVERTIBLE INLINE POPPET, SPRING RETURN, NAMUR SINGLE SOLENOID VALVE

DIMENSIONS

All Dimensions are in mm

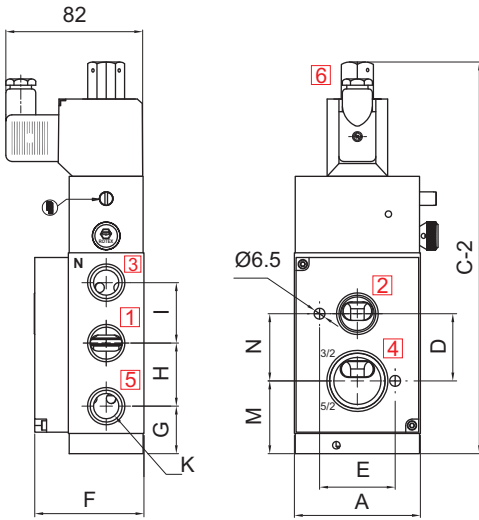

Valve Type	51450V02, 51450, 51450LW, 51450V02LW,
Enclosure Type	22
Enclosure Size	I
Port Connection	1/4", 1/2"
Body Material	Aluminium, SS

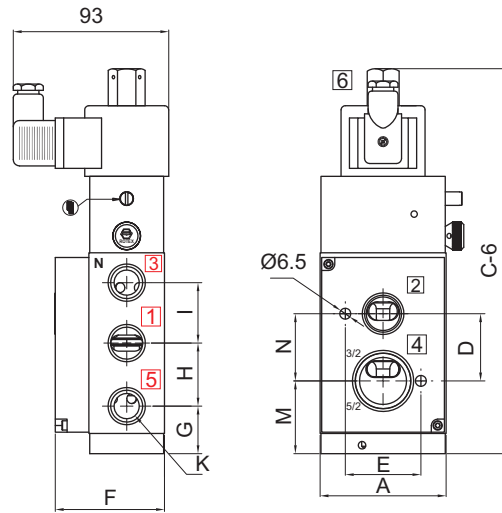

Valve Type	51450V02, 51450, 51450V02LW, 51450V02IS, 51450LW, 51450V02L4, 51450L4, 51450IS, 51450IR, 51450V02IR
Enclosure Type	25, 65CR
Enclosure Size	III
Port Connection	1/4", 1/2"
Body Material	Aluminium, SS

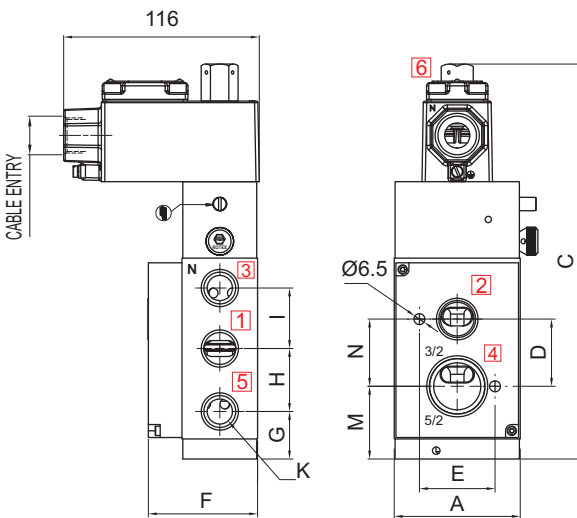

Valve Type	51450V02, 51450, 51450LW, 51450V02LW
Enclosure Type	16, 19, 37, 39, 58, 58LT
Enclosure Size	I
Port Connection	1/4", 1/2"
Body Material	Aluminium, SS

Valve Type : 51450V02, 51450, 51450V02LW, 51450V02IS, 51450LW, 51450V02L4, 51450L4, 51450IS, 51450IR, 51450V02IR											
NW	K	A	C	D	E	F	G	H	I	M	N
6	1/4"	53	198	24	32	48	25	24	24	38	22.5
12	1/2"	75	235	40	45	65	28	37.5	36	43	40

SERIES : 52S

5/2, 3/2 CONVERTIBLE INLINE POPPET, SPRING RETURN, NAMUR SINGLE SOLENOID VALVE

DIMENSIONS All Dimensions are in mm

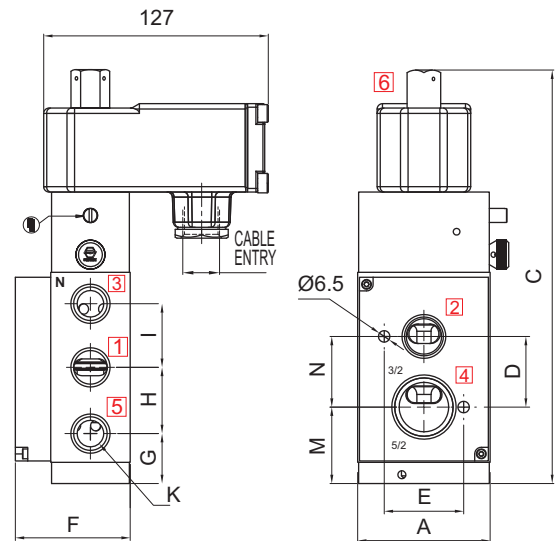
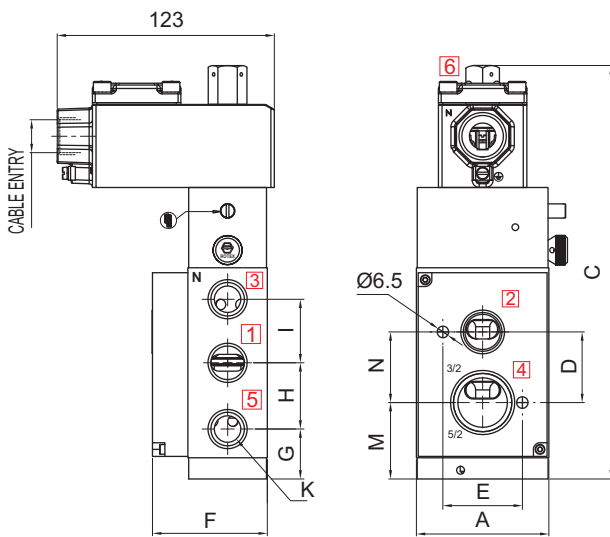

Valve Type	51450V02, 51450, 51450V02LW, 51450V02IS, 51450LW, 51450V02L4, 51450L4, 51450IS, 51450IR, 51450V02IR
Enclosure Type	16, 19, 37, 39, 58, 58LT, 67
Enclosure Size	III
Port Connection	1/4", 1/2"
Body Material	Aluminium, SS

Valve Type	51450V02, 51450, 51450V02LW, 51450V02IS, 51450LW, 51450V02L4, 51450L4, 51450IS, 51450IR, 51450V02IR
Enclosure Type	17, 87, 66, 71
Enclosure Size	III
Port Connection	1/4", 1/2"
Body Material	Aluminium, SS

Valve Type : 51450V02, 51450, 51450V02LW, 51450V02IS, 51450LW, 51450V02L4, 51450L4, 51450IS, 51450IR, 51450V02IR											
NW	K	A	C	D	E	F	G	H	I	M	N
6	1/4"	53	198	24	32	48	25	24	24	38	22.5
12	1/2"	75	235	40	45	65	28	37.5	36	43	40



ROTEX AUTOMATION LIMITED

SALES HQ

B/703/704, Western Edge-II,
Off Western Express Highway,
Borivali (East), Mumbai-400066
Ph: +91 22 42111444
Fax: +91 22 42111400

OVERSEAS:

Bier Straat 117
3011 XA
Rotterdam
The Netherlands
Phone : +31 88 505 35 05
Email : info@rotexcontrols.nl

WORKS

UNIT 1

987/11, GIDC Makarpura,
Vadodara - 390010, Gujarat, INDIA.
Ph. : +91 265 2638136/ 2638795/ 46
Fax : +91 265 2638130

UNIT 2

C - 1 B/ 1501, 4 & 5, GIDC
Vithal Udyognagar - 388121,
Gujarat, INDIA.
Ph. : +91 2692 236224/ 236292/ 236399
Fax : +91 2692 236442