

# E P3E 10k Choke 5CB

10 000 psig / Max Cv 83 / Max Bean Size 137



## VALVE SPECIFICATIONS

This choke-valve option, with a higher maximum pressure rating, uses a bolted bonnet to retain the flow trim in the valve body. The flow trim is pressure balanced to minimize the stem loads and provide low operating torques. Standard end connections range in size from 2-1/2" to 4".

Valve Model	P3E 10k
Body Type	Right Angle
Body Rating	10 000 PSIG (Maximum C.W.P.)
Inlet Connection	see 'Standard End Connections'
Outlet Connection	see 'Standard End Connections'
Bonnet Type	Bolted
Body / Bonnet Material	see 'Material Options'
Stem Material	see 'Material Options'
Seal Material	see 'Material Options'
Trim Style	Ported Cage with External Sleeve
Balanced / Unbalanced	Balanced
Flow Characteristic	Equal Percentage
Trim Material	see 'Trim Options'
Design Cv	see 'Trim Options'
Leakage Class	Class V (Standard)

## TRIM OPTIONS

	Standard Trim Cage & External Sleeve 2 Row / 4 Hole	Multistage Trim	High-Pressure Multi-stage Trim
Material	UNS S17400, Stellite, Tungsten Carbide	Stellite, Tungsten Carbide	Stellite, Tungsten Carbide
Application	Liquid, Gas, Multiphase; Abrasive	Liquid, Gas, Multiphase	Liquid, Gas, Multiphase
Cv	83	25	17
Turns	17	12	12
Travel	2.15"	1.45"	1.45"

## STANDARD END CONNECTIONS

Connection Size ▶	Standard Dimensions & Estimated Weights											
	2-1/2" Nominal				3" Nominal				4" Nominal			
	'I' or 'O'		Weight		'I' or 'O'		Weight		'I' or 'O'		Weight	
Connection Type ▼	inch	mm	lbs.	kg	inch	mm	lbs.	kg	inch	mm	lbs.	kg
ASME 150 RF	n/a	n/a	n/a	n/a	9.25	235	361	164	9.50	241	371	168
ASME 300 RF	n/a	n/a	n/a	n/a	9.62	244	374	170	9.88	251	391	178
ASME 600 RF	n/a	n/a	n/a	n/a	10.00	254	407	185	10.75	273	476	216
ASME 600 RTJ	n/a	n/a	n/a	n/a	10.06	256	407	185	10.81	275	476	216
ASME 900 RF	n/a	n/a	n/a	n/a	10.75	273	418	190	11.25	286	490	222
ASME 900 RTJ	n/a	n/a	n/a	n/a	10.81	275	418	190	11.31	287	490	222
ASME 1500 RF	n/a	n/a	n/a	n/a	11.38	289	438	199	11.62	295	509	231
ASME 1500 RTJ	n/a	n/a	n/a	n/a	11.44	291	438	199	11.69	297	509	231
ASME 2500 RTJ	n/a	n/a	n/a	n/a	13.50	343	526	239	14.44	367	630	286
2 000 API 6B	9.94	252	366	166	10.06	256	407	185	10.81	275	476	216
3 000 API 6B	10.94	278	405	184	10.81	275	418	190	11.31	287	490	222
5 000 API 6B	10.94	278	405	184	11.44	291	438	199	11.69	297	509	231
10 000 API 6BX	11.38	289	410	185	12.00	305	441	200	13.00	330	541	246

## ENVELOPE DIMENSIONS

Dimensions 'A', 'B', and 'C' apply to manually operated chokes and are tabulated below. 'I' (inlet) and 'O' (outlet) dimensions depend on the end connections and are tabulated above. Special dimensions and other end connections are available upon request.

Dimensions		
	inch	mm
A	17.50	445
B	18.00	457
C	25.00	635

Note: "C" is the disassembly clearance.

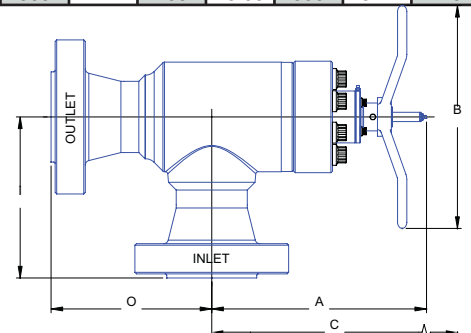

**MATERIAL OPTIONS**

Temperature Class	Certification Level	API - 6A Material Class Designations						
		AA	BB	CC	DD	EE	FF	HH
PU -20F to 250F	STD / PSL-1	BB	BB	FF	EE	EE	FF	HH
	PSL-2	EE	EE	FF	EE	EE	FF	HH
	PSL-3	EE	EE	FF	EE	EE	FF	HH
LU -50F to 250F	STD / PSL-1	EE	EE	FF	EE	EE	FF	HH
	PSL-2	EE	EE	FF	EE	EE	FF	HH
	PSL-3	EE	EE	FF	EE	EE	FF	HH

	BB-General Service	EE-Sour Service	FF-Sour Service	HH-Sour Service
Body	AISI 8620	AISI 8620	UNS S31803	AISI 8620 / Inconel 625
Bonnet	AISI 4130	AISI 4130	AISI 4130 / NS S31803	AISI 4130 / Inconel 625
Stem	UNS S17400	UNS S17400	UNS S17400	Inconel 718
Bolting	ASTM A320 L7M	ASTM A320 L7M	ASTM A320 L7M	ASTM A320 L7M
Retaining Sleeve	ASTM A743 CF8M	ASTM A743 CF8M	ASTM A743 CF8M	Inconel 625
Balance Sleeve	UNS S31803	UNS S31803	UNS S31803	Inconel 625
Seals	Buna - N	Viton	Viton	Teflon

Other materials available upon request.

**OTHER VALVE OPTIONS**

	Standard	Optional
Calibration Head / Serial Plaque	Aluminum	Stainless Steel
Outlet Sleeve	-	Tungsten Carbide
Body Bleed Port	-	API Autoclave

Some limitations may apply.

**ACTUATION OPTIONS**

Master Flo	Other
Manually Operated (Stemlock is optional)	Rotary Electric
Rotary Stepping (Pneumatic)	Pneumatic Piston
Rotary Stepping (Hydraulic)	Electro-Hydraulic Piston
FC Hydraulic Piston	
Pneumatic Piston	

Other actuators available upon request.

**PERFORMANCE CHARACTERISTICS**

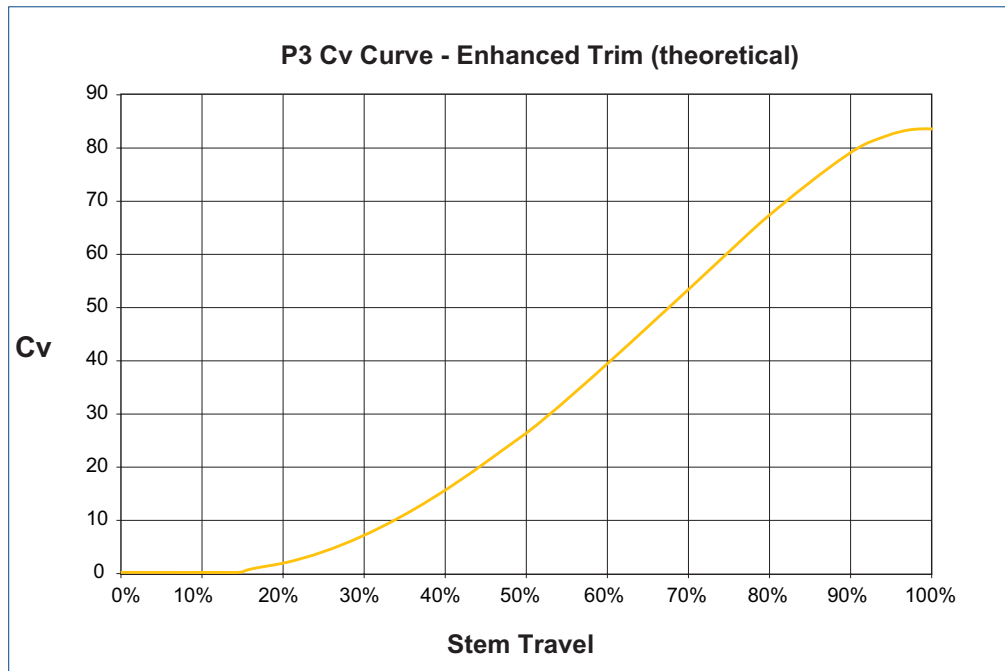

**LIQUID PRESSURE RECOVERY FACTOR (FL)**

Master Flo's trim geometry has been designed to achieve high  $F_L$  numbers. This results in a decreased cavitation potential, lower noise generation, increased flow capacity, and longer trim life. The high  $F_L$  numbers of Master Flo's trims have been verified experimentally as per the test procedures of ISA-S75.02-1996.

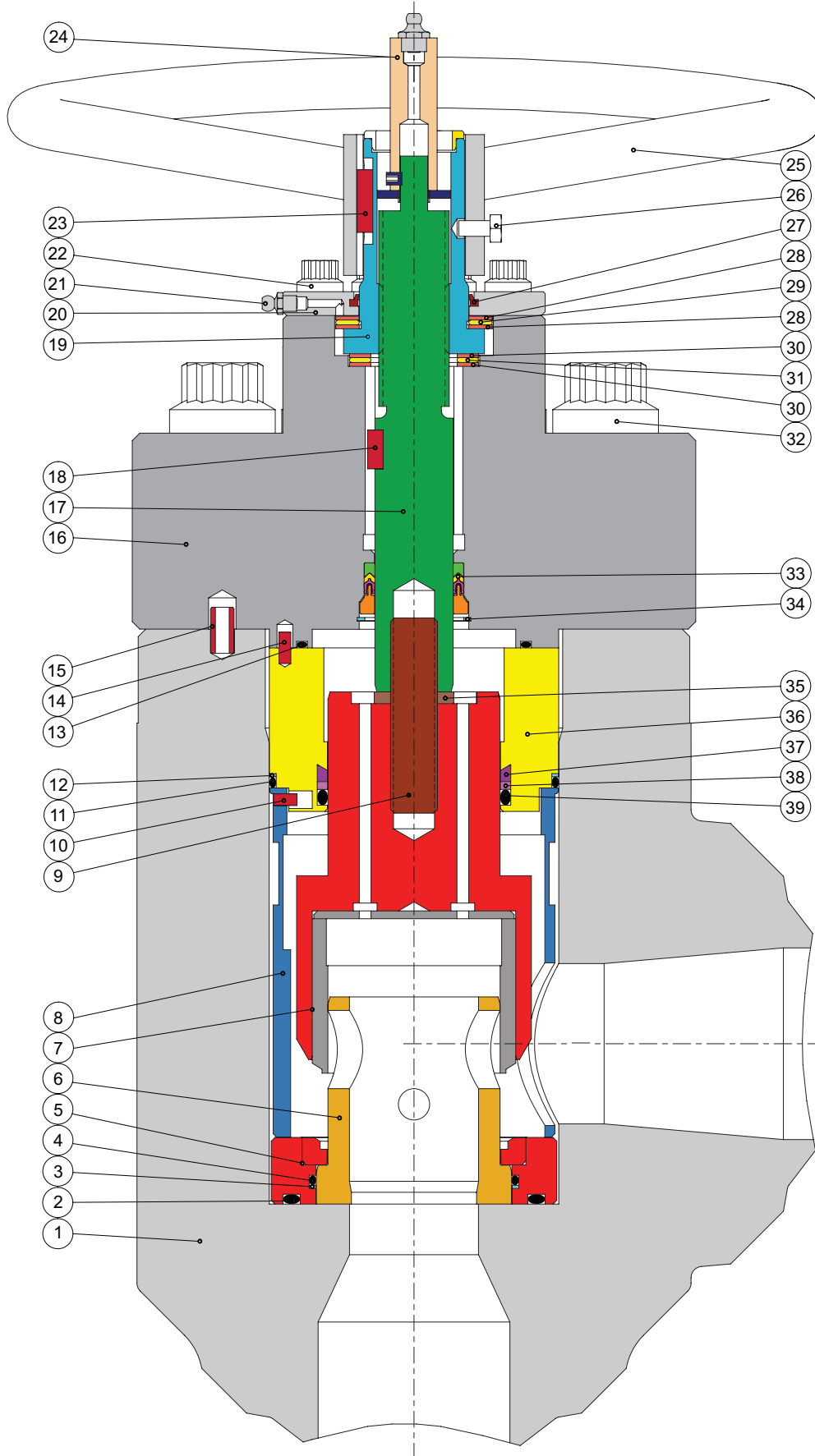

**PARTS LIST**

- 1. Body
- 2. Seal: Seat - Body
- 3. B/U Ring: Cage - Seat
- 4. Seal: Cage - Seat
- 5. Seat
- 6. Cage
- 7. External Sleeve
- 8. Retaining Sleeve
- 9. Stud
- 10. Pin
- 11. Seal: Balance Sleeve - Body
- 12. B/U Ring: Balance Sleeve - Body
- 13. Seal: Balance Sleeve - Bonnet
- 14. Pin
- 15. Spring Pin
- 16. Bonnet
- 17. Stem
- 18. Key
- 19. Stem Nut
- 20. Cover Plate
- 21. Grease Nipple
- 22. Capscrew
- 23. Key
- 24. Calibration Head
- 25. Handwheel
- 26. Capscrew
- 27. Wiper
- 28. Thrust Washer
- 29. Thrust Bearing
- 30. Thrust Washer
- 31. Thrust Bearing
- 32. Capscrew
- 33. Seal Pack: Stem - Bonnet
- 34. Retaining Ring
- 35. Lockwasher
- 36. Balance Sleeve
- 37. External-Sl. Bushing
- 38. B/U Ring: External Sl. - Balance Sl.
- 39. Seal: External Sl. - Balance Sl.

**P3 Product Family**

*Standard:*  
 • P3E - Bolted Bonnet; 6 000 PSI

*Other Options:*  
 • P3E 10k - Bolted Bonnet; 10 000 PSI  
 • P3E HT - Bolted Bonnet; 3 600 PSI;  
 High-Temperature Service  
 • C3E - Bolted Bonnet; 3 600 PSI; Inline  
 • C3E HT - Bolted Bonnet; 3 600 PSI;  
 High-Temperature Service

**chokes**  
for all applications

recycle lines



vent valves



manifold



production



blow down

glycol injection

overboard dumps



subsea



level controllers

water injection



[www.masterflo.com](http://www.masterflo.com)  
[info@masterflo.com](mailto:info@masterflo.com)  
[info@masterflo.co.uk](mailto:info@masterflo.co.uk)