

P8 Choke 5CB

6 000 psig / Max Cv 700 / Max Bean Size 450

VALVE SPECIFICATIONS ▶

Valve Model	P8E
Body Type	Right Angle
Body Rating	6 000 PSIG (Maximum C.W.P.)
Inlet Connection	see 'Standard End Connections'
Outlet Connection	see 'Standard End Connections'
Bonnet Type	Bolted
Body / Bonnet Material	see 'Material Options'
Stem Material	see 'Material Options'
Seal Material	see 'Material Options'
Trim Style	Ported Cage with External Sleeve
Balanced / Unbalanced	Balanced
Flow Characteristic	Equal Percentage
Trim Material	see 'Trim Options'
Design Cv	see 'Trim Options'
Leakage Class	Class V (Standard)

TRIM OPTIONS ▶

	Standard Trim Cage & External Sleeve 2 Row / 4 Hole
Material	UNS S17400, Stellite, Tungsten Carbide
Application	Liquid, Gas, Multiphase; Abrasive*
Cv	700
Turns	34.5
Travel	5.75"

* For abrasive service, tungsten carbide is recommended.



STANDARD END CONNECTIONS ▶

Connection Size ▶	Standard Dimensions & Estimated Weights							
	8" Nominal				10" Nominal			
	'I' or 'O'		Weight		'I' or 'O'		Weight	
Connection Type ▼	inch	mm	lbs.	kg	inch	mm	lbs.	kg
ASME 150 RF	15.25	387	1365	620	15.25	387	1405	640
ASME 300 RF	15.62	397	1420	645	15.88	403	1490	675
ASME 600 RF	16.75	425	1505	685	17.50	445	1690	768
ASME 600 RTJ	16.81	427	1505	685	17.56	446	1690	768
ASME 900 RF	17.88	454	1655	750	18.75	476	1835	835
ASME 900 RTJ	17.94	456	1655	750	18.81	478	1835	835
ASME 1500 RF	19.88	505	1825	830	21.50	546	2310	1050
ASME 1500 RTJ	20.06	510	1825	830	21.69	551	2300	1050
ASME 2500 RTJ	24.31	618	2430	1105	28.44	722	3295	1495
2 000 API 6B	16.81	427	1505	685	17.56	446	1675	760
3 000 API 6B	17.94	456	1655	750	18.81	478	1860	845
5 000 API 6B	20.06	510	1825	830	21.69	551	2310	1050

ENVELOPE DIMENSIONS ▶

Dimensions 'A', 'B', and 'C' apply to manually operated chokes and are tabulated below. 'I' (inlet) and 'O' (outlet) dimensions depend on the end connections and are tabulated above. Special dimensions and other end connections are available upon request.

Dimensions		
	inch	mm
A	34.00	864
B	28.00	711
C	49.12	1248

Note: "C" is the disassembly clearance.

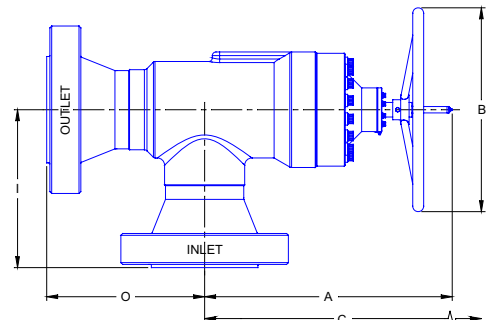

MATERIAL OPTIONS

Temperature Class	Certification Level	API - 6A Material Class Designations						
		AA	BB	CC	DD	EE	FF	HH
PU -20F to 250F	STD / PSL-1	BB	BB	FF	EE	EE	FF	HH
	PSL-2	EE	EE	FF	EE	EE	FF	HH
	PSL-3	EE	EE	FF	EE	EE	FF	HH
LU -50F to 250F	STD / PSL-1	EE	EE	FF	EE	EE	FF	HH
	PSL-2	EE	EE	FF	EE	EE	FF	HH
	PSL-3	EE	EE	FF	EE	EE	FF	HH

	BB-General Service	EE-Sour Service	FF-Sour Service	HH-Sour Service
Body	ASTM A487 4C	ASTM A487 4C	ASTMA487 4C / Inconel 625	ASTM A487 4C / Inconel 625
Bonnet	ASTM A350 LF2	AISI 4130	AISI 316	Inconel 625
Stem	UNS S17400	UNS S17400	UNS S17400	Inconel 718
Bolting	ASTM A320 L7M	ASTM A320 L7M	ASTM A320 L7M	ASTM A320 L7M
Retaining Sleeve	ASTM A743 CF8M	ASTM A743 CF8M	ASTM A743 CF8M	Inconel 625
Balance Sleeve	AISI 316	ASTM A487 CA6NM	UNS S31803	Inconel 625
Seals	Buna - N	Viton	Viton	Teflon

Other materials available upon request.

OTHER VALVE OPTIONS

	Standard	Optional
Calibration Head / Serial Plaque	Aluminum	Stainless Steel
Outlet Sleeve	Stainless Steel	Tungsten Carbide
Body Bleed Port	-	-

Some limitations may apply.

ACTUATION OPTIONS

Master Flo	Other
Manually Operated (Stemlock is optional)	Rotary Electric
Rotary Stepping (Pneumatic)	
Rotary Stepping (Hydraulic)	
FC Hydraulic Piston	

Other actuators available upon request.

PERFORMANCE CHARACTERISTICS

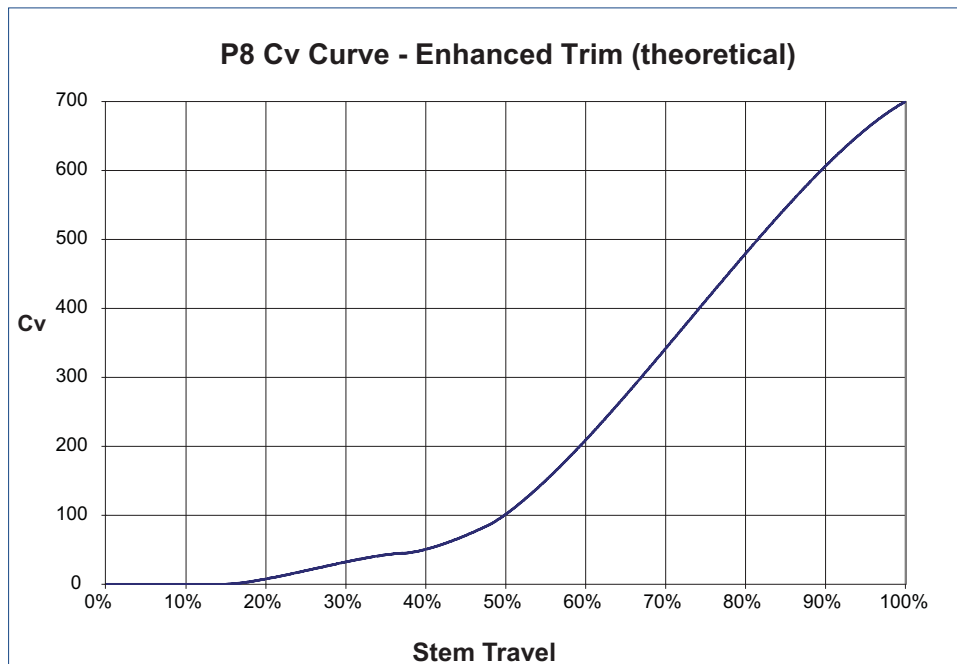

LIQUID PRESSURE RECOVERY FACTOR (FL)

Master Flo's trim geometry has been designed to achieve high F_L numbers. This results in a decreased cavitation potential, lower noise generation, increased flow capacity, and longer trim life. The high F_L numbers of Master Flo's trims have been verified experimentally as per the test procedures of ISA-S75.02-1996.

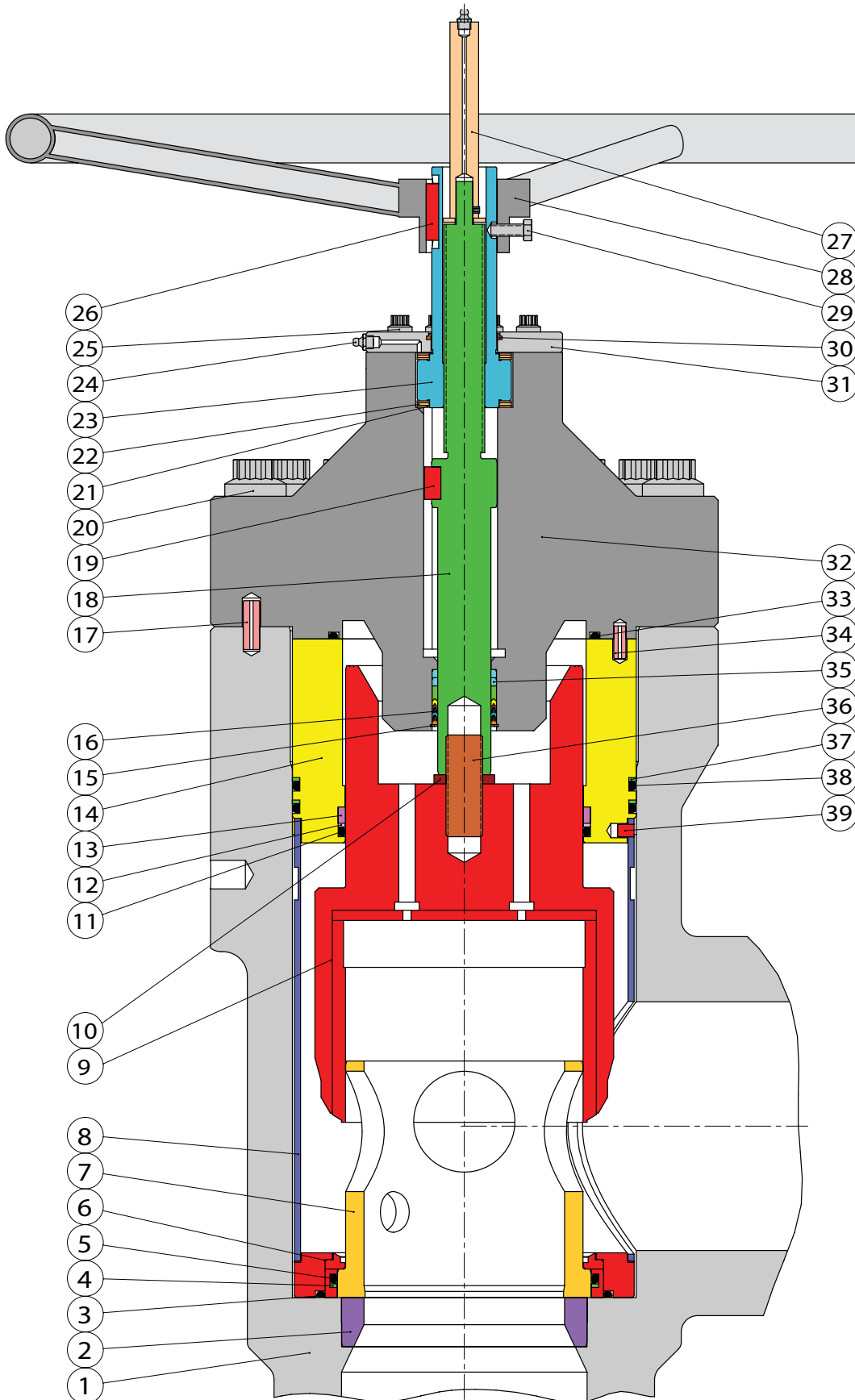

PARTS LIST

1. Body
2. Outlet Sleeve
3. Seal: Seat - Body
4. B/U Ring: Nozzle - Seat
5. Seal: Nozle - Seat
6. Seat
7. Cage
8. Retaining Sleeve
9. External Sleeve
10. Lockwasher
11. Seal: External Sl. - Balance Sl.
12. B/U Ring: External Sl. - Balance Sl.
13. External-Sleeve Bushing
14. Balance Sleeve
15. Retaining Ring
16. Seal: Stem - Bonnet
17. Spring Pin
18. Stem
19. Key
20. Capscrew
21. Thrust Washer
22. Thrust Bearing
23. Stem Nut
24. Grease Nipple
25. Capscrew
26. Key
27. Calibration Head
28. Handwheel
29. Capscrew
30. Wiper
31. Cover Plate
32. Bonnet
33. Seal: Balance Sleeve - Bonnet
34. Spring Pin
35. Stem Bushing
36. Stud
37. B/U Ring: Balance Sleeve - Body
38. Seal: Balance Sleeve - Body
39. Pin

chokes
for all applications

recycle lines



vent valves



manifold



production



blow down

glycol injection

overboard dumps



subsea



level controllers

water injection



www.masterflo.com
info@masterflo.com
info@masterflo.co.uk