

# P4E Choke 5CB

6 000 psig / Max Cv 205 / Max Bean Size 216



## VALVE SPECIFICATIONS ▶

Valve Model	P4E
Body Type	Right Angle
Body Rating	6 000 PSIG (Maximum C.W.P.)
Inlet Connection	see 'Standard End Connections'
Outlet Connection	see 'Standard End Connections'
Bonnet Type	Bolted
Body / Bonnet Material	see 'Material Options'
Stem Material	see 'Material Options'
Seal Material	see 'Material Options'
Trim Style	Ported Cage with External Sleeve
Balanced / Unbalanced	Balanced
Flow Characteristic	Equal Percentage
Trim Material	see 'Trim Options'
Design Cv	see 'Trim Options'
Leakage Class	Class V (Standard)

## TRIM OPTIONS ▶

	Standard Trim Cage & External Sleeve 2 Row / 4 Hole	Multistage Trim	High-Pressure Multi-stage Trim
Material	UNS S17400, Stellite, Tungsten Carbide	Stellite, Tungsten Carbide	Stellite, Tungsten Carbide
Application	Liquid, Gas, Multiphase; Abrasive	Liquid, Gas, Multiphase	Liquid, Gas, Multiphase
Cv	205	54	35
Turns	20	15	15
Travel	3.35"	2.55"	2.55"

## STANDARD END CONNECTIONS ▶

Connection Size ▶	Standard Dimensions & Estimated Weights											
	4" Nominal				5" Nominal				6" Nominal			
	'I' or 'O'		Weight		'I' or 'O'		Weight		'I' or 'O'		Weight	
Connection Type ▼	inch	mm	lbs.	kg	inch	mm	lbs.	kg	inch	mm	lbs.	kg
ASME 150 RF	9.50	241	410	185	10.00	254	420	190	10.00	254	430	195
ASME 300 RF	9.88	251	430	195	10.38	264	450	205	10.38	264	470	215
ASME 600 RF	10.75	273	455	205	11.25	286	510	230	11.38	289	535	245
ASME 600 RTJ	10.81	275	455	205	11.31	287	510	230	11.44	291	535	245
ASME 900 RF	11.25	286	480	220	11.75	298	540	245	12.25	311	590	270
ASME 900 RTJ	11.31	287	480	220	11.81	300	540	245	12.31	313	590	270
ASME 1500 RF	11.62	295	520	235	12.88	327	645	295	13.50	343	700	320
ASME 1500 RTJ	11.69	297	520	235	12.94	329	645	295	13.62	346	700	320
ASME 2500 RTJ	14.44	367	645	295	16.00	406	820	375	17.75	451	1070	485
2 000 API 6B	10.81	275	455	205	11.31	287	510	230	11.44	291	535	245
3 000 API 6B	11.31	287	485	220	11.81	300	550	250	12.31	313	605	275
5 000 API 6B	11.69	297	520	235	12.94	329	645	295	13.62	346	700	320

## ENVELOPE DIMENSIONS ▶

Dimensions 'A', 'B', and 'C' apply to manually operated chokes and are tabulated below. 'I' (inlet) and 'O' (outlet) dimensions depend on the end connections and are tabulated above. Special dimensions and other end connections are available upon request.

Dimensions		
	inch	mm
A	26.00	660
B	18.00	457
C	37.62	956

**Note:** "C" is the disassembly clearance.

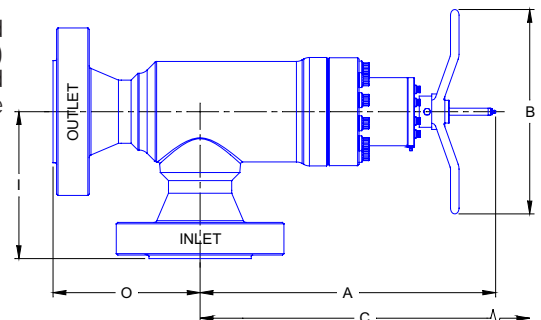

**MATERIAL OPTIONS**

Temperature Class	Certification Level	API - 6A Material Class Designations							
		AA	BB	CC	DD	EE	FF	HH	
PU -20F to 250F PX -20F to 350F	STD / PSL-1	BB	BB	FF	EE	EE	FF	HH	
	PSL-2	EE	EE	FF	EE	EE	FF	HH	
	PSL-3	EE	EE	FF	EE	EE	FF	HH	
LU -50F to 250F	STD / PSL-1	EE	EE	FF	EE	EE	FF	HH	
	PSL-2	EE	EE	FF	EE	EE	FF	HH	
	PSL-3	EE	EE	FF	EE	EE	FF	HH	

	BB-General Service	EE-Sour Service	FF-Sour Service	HH-Sour Service
<b>Body</b>	AISI 8620	AISI 8620	UNS S31803	AISI 8620 / Inconel 625
<b>Bonnet</b>	AISI 4130	AISI 4130	AISI 4130 / UNS S31803	AISI 4130 / Inconel 625
<b>Stem</b>	UNS S17400	UNS S17400	UNS S17400	Inconel 718
<b>Bolting</b>	ASTM A320 L7M	ASTM A320 L7M	ASTM A320 L7M	ASTM A320 L7M
<b>Retaining Sleeve</b>	ASTM A743 CF8M	ASTM A743 CF8M	ASTM A743 CF8M	Inconel 625
<b>Balance Sleeve</b>	UNS S42400	UNS S42400	UNS S31803	Inconel 625
<b>Seals</b>	Buna - N	Viton	Viton	Teflon

Other materials available upon request.

**OTHER VALVE OPTIONS**

	Standard	Optional
<b>Calibration Head / Serial Plaque</b>	Aluminum	Stainless Steel
<b>Outlet Sleeve</b>	-	Stainless Steel , Tungsten Carbide
<b>Body Bleed Port</b>	-	1/2" NPT, API Autoclave

Some limitations may apply.

**ACTUATION OPTIONS**

Master Flo	Other
Manually Operated (Stemlock is optional)	Rotary Electric
Rotary Stepping (Pneumatic)	Rotary Stepping (Pneumatic)
Rotary Stepping (Hydraulic)	Pneumatic Diaphragm
FC Hydraulic Piston	Pneumatic Piston
Pneumatic Piston	Electro-Hydraulic Piston

Other actuators available upon request.

**PERFORMANCE CHARACTERISTICS**

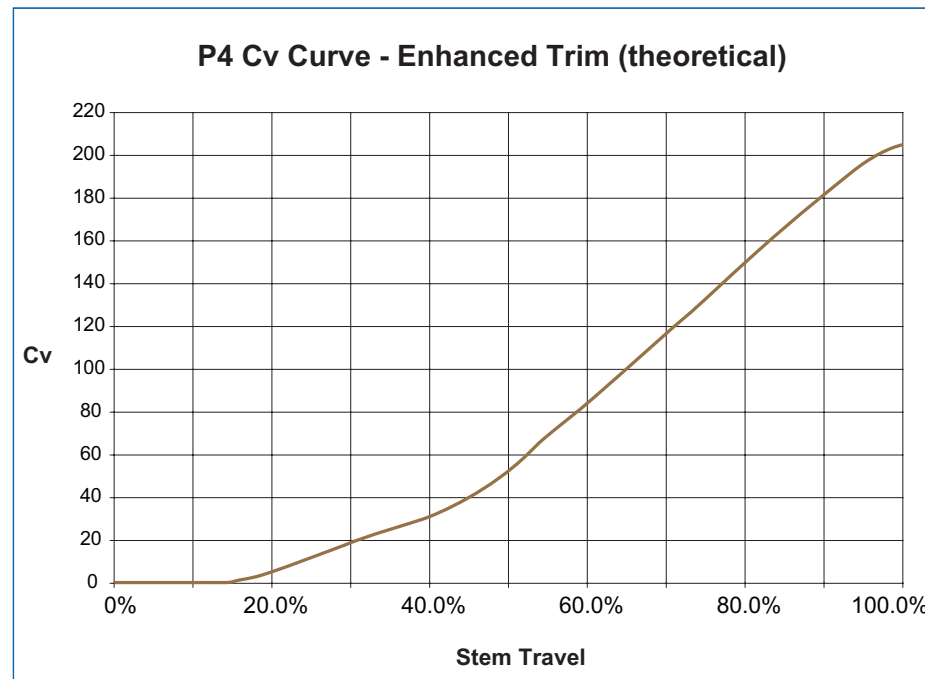

**LIQUID PRESSURE RECOVERY FACTOR (FL)**

Master Flo's trim geometry has been designed to achieve high  $F_L$  numbers. This results in a decreased cavitation potential, lower noise generation, increased flow capacity, and longer trim life. The high  $F_L$  numbers of Master Flo's trims have been verified experimentally as per the test procedures of ISA-S75.02-1996.

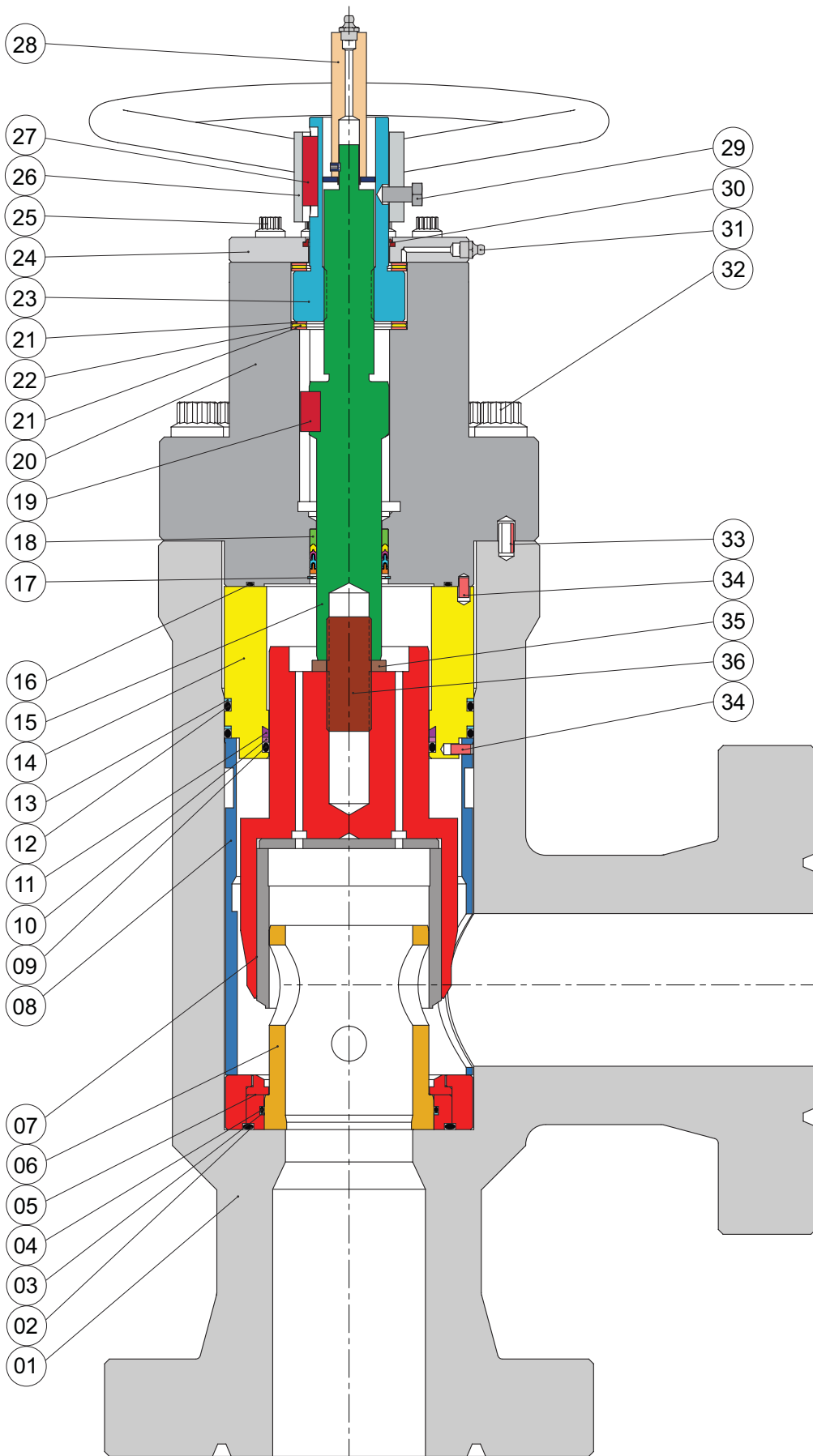

### PARTS LIST

- 1. Body
- 2. Seal: Seat - Body
- 3. B/U Ring: Cage - Seat
- 4. Seal: Cage - Seat
- 5. Seat
- 6. Cage
- 7. External Sleeve
- 8. Retaining Sleeve
- 9. Seal: External Sl. - Balance Sleeve
- 10. B/U Ring: External Sl. - Balance Sl.
- 11. Bushing: External Sl. - Balance Sl.
- 12. Seal: Balance Sleeve - Body
- 13. B/U Ring: Balance Sleeve - Body
- 14. Balance Sleeve
- 15. Stem
- 16. Seal: Balance Sleeve - Bonnet
- 17. Retaining Ring
- 18. Seal Pack: Stem - Bonnet
- 19. Key
- 20. Bonnet
- 21. Thrust Washer
- 22. Thrust Bearing
- 23. Stem Nut
- 24. Cover Plate
- 25. Capscrew
- 26. Handwheel
- 27. Key
- 28. Calibration Head
- 29. Capscrew
- 30. Wiper
- 31. Grease Nipple
- 32. Capscrew
- 33. Spring Pin
- 34. Groove Pin
- 35. Lockwasher
- 36. Stud

### P4 Product Family

#### Standard:

- P4E - Bolted Bonnet; 6000 PSI

#### Other Options:

- P4E 10k - Bolted Bonnet; 10000 PSI
- C4E - Bolted Bonnet; 3600 PSI; Inline

## chokes for all applications

recycle lines



vent valves



manifold



production



blow down

glycol injection

overboard dumps



subsea



level controllers

water injection



[www.masterflo.com](http://www.masterflo.com)  
[info@masterflo.com](mailto:info@masterflo.com)  
[info@masterflo.co.uk](mailto:info@masterflo.co.uk)