

E P3E Choke 5CB

6 000 psig / Max Cv 83 / Max Bean Size 137

VALVE SPECIFICATIONS

This choke valve uses a bolted bonnet to retain the flow trim in the valve body. The flow trim is pressure balanced to minimize the stem loads and provide low operating torques. Standard end connections range in size from 3" to 4".



Valve Model	P3E
Body Type	Right Angle
Body Rating	6 000 PSIG (Maximum C.W.P.)
Inlet Connection	see 'Standard End Connections'
Outlet Connection	see 'Standard End Connections'
Bonnet Type	Bolted
Body / Bonnet Material	see 'Material Options'
Stem Material	see 'Material Options'
Seal Material	see 'Material Options'
Trim Style	Ported Cage with External Sleeve
Balanced / Unbalanced	Balanced
Flow Characteristic	Equal Percentage
Trim Material	see 'Trim Options'
Design Cv	see 'Trim Options'
Leakage Class	Class V (Standard)

TRIM OPTIONS

	Standard Trim Cage & External Sleeve 2 Row / 4 Hole	Multistage Trim	High-Pressure Multi-stage Trim
Material	UNS S17400, Stellite, Tungsten Carbide	Stellite, Tungsten Carbide	Stellite, Tungsten Carbide
Application	Liquid, Gas, Multiphase; Abrasive	Liquid, Gas, Multiphase	Liquid, Gas, Multiphase
Cv	83	25	17
Turns	17	12	12
Travel	2.15"	1.45"	1.45"

STANDARD END CONNECTIONS

Connection Size ▶	Standard Dimensions & Estimated Weights							
	3" Nominal				4" Nominal			
	'I' or 'O'		Weight		'I' or 'O'		Weight	
Connection Type ▼	inch	mm	lbs.	kg	inch	mm	lbs.	kg
Threaded	5.25	133	154	70	n/a	n/a	n/a	n/a
ASME 150 RF	8.00	203	177	80	8.25	210	187	85
ASME 300 RF	8.38	213	190	86	8.62	219	207	94
ASME 600 RF	8.75	222	190	86	9.50	241	228	104
ASME 600 RTJ	8.81	224	190	86	9.56	243	228	104
ASME 900 RF	9.50	241	212	96	10.00	254	256	116
ASME 900 RTJ	9.56	243	212	96	10.06	256	256	116
ASME 1500 RF	10.12	257	250	114	10.38	264	292	133
ASME 1500 RTJ	10.19	259	250	114	10.44	265	292	133
ASME 2500 RTJ	12.25	311	342	155	13.19	335	446	202
2 000 API 6B	8.81	224	190	86	9.56	243	228	104
3 000 API 6B	9.56	243	212	96	10.06	256	256	116
5 000 API 6B	10.19	259	250	114	10.44	265	292	133

ENVELOPE DIMENSIONS

Dimensions 'A', 'B', and 'C' apply to manually operated chokes and are tabulated below. 'I' (inlet) and 'O' (outlet) dimensions depend on the end connections and are tabulated above. Special dimensions and other end connections are available upon request.

Dimensions		
	inch	mm
A	17.50	445
B	18.00	457
C	25.00	635

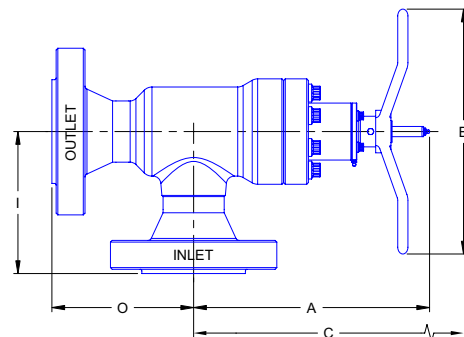

Note: "C" is the disassembly clearance.



MATERIAL OPTIONS

Temperature Class	Certification Level	API - 6A Material Class Designations							
		AA	BB	CC	DD	EE	FF	HH	
PU -20F to 250F PX -20F to 350F	STD / PSL-1	BB	BB	FF	EE	EE	FF	HH	
	PSL-2	EE	EE	FF	EE	EE	FF	HH	
	PSL-3	EE	EE	FF	EE	EE	FF	HH	
LU -50F to 250F	STD / PSL-1	EE	EE	FF	EE	EE	FF	HH	
	PSL-2	EE	EE	FF	EE	EE	FF	HH	
	PSL-3	EE	EE	FF	EE	EE	FF	HH	

	BB-General Service	EE-Sour Service	FF-Sour Service	HH-Sour Service
Body	AISI 8620	AISI 8620	UNS S31803	AISI 8620 / Inconel 625
Bonnet	ASTM A350 LF2 or AISI 4130	ASTM A350 LF2 or AISI 4130	ASTMA350 LF2 or AISI 4130 / UNS S31803	ASTM A350 LF2 or AISI 4130 / Inconel 625
Stem	UNS S17400	UNS S17400	UNS S17400	Inconel 718
Bolting	ASTM A320 L7M	ASTM A320 L7M	ASTM A320 L7M	ASTM A320 L7M
Retaining Sleeve	ASTM A743 CF8M	ASTM A743 CF8M	ASTM A743 CF8M	Inconel 625
Balance Sleeve	UNS S42400	UNS S42400	UNS S31803	Inconel 625
Seals	Buna - N	Viton	Viton	Teflon

Other materials available upon request.

OTHER VALVE OPTIONS

	Standard	Optional
Calibration Head / Serial Plaque	Aluminum	Stainless Steel
Outlet Sleeve	-	Stainless Steel, Tungsten Carbide
Body Bleed Port	-	½" NPT, API Autoclave

Some limitations may apply.

ACTUATION OPTIONS

Master Flo	Other
Manually Operated (Stemlock is optional)	Rotary Electric
Rotary Stepping (Pneumatic)	Pneumatic Diaphragm
Rotary Stepping (Hydraulic)	Pneumatic Piston
FC Hydraulic Piston	Electro-Hydraulic Piston
Pneumatic Piston	

Other actuators available upon request.

PERFORMANCE CHARACTERISTICS

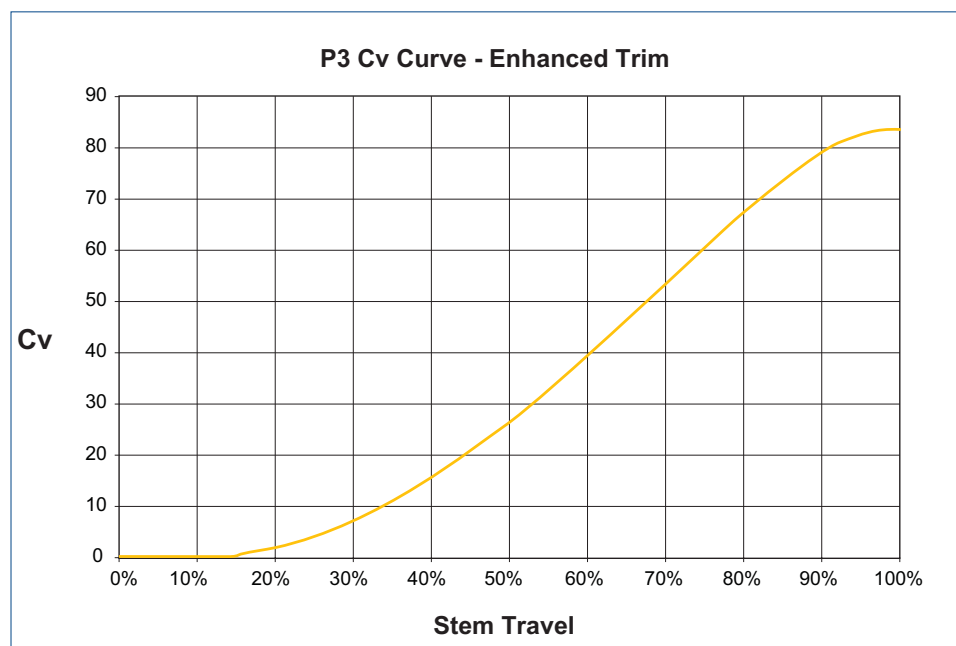

LIQUID PRESSURE RECOVERY FACTOR (FL)

Master Flo's trim geometry has been designed to achieve high F_L numbers. This results in a decreased cavitation potential, lower noise generation, increased flow capacity, and longer trim life. The high F_L numbers of Master Flo's trims have been verified experimentally as per the test procedures of ISA-S75.02-1996.

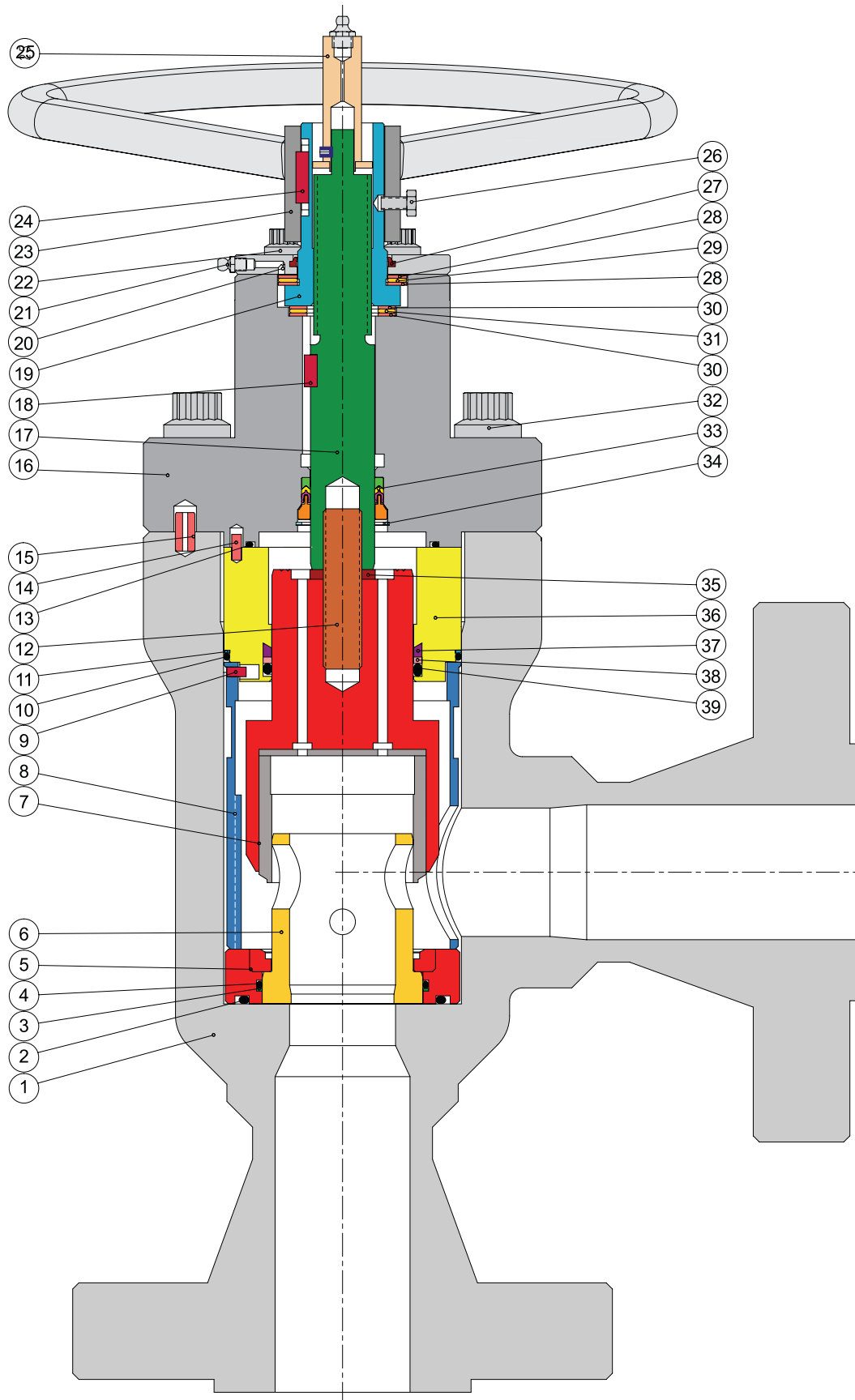

PARTS LIST

1. Body
2. Seal: Seat - Body
3. B/U Ring: Cage - Seat
4. Seal: Cage - Seat
5. Seat
6. Cage
7. External Sleeve
8. Retaining Sleeve
9. Pin
10. Seal: Balance Sleeve - Body
11. B/U Ring: Balance Sleeve - Body
12. Stud
13. Seal: Balance Sleeve - Bonnet
14. Pin
15. Spring Pin
16. Bonnet
17. Stem
18. Key
19. Stem Nut
20. Cover Plate
21. Grease Nipple
22. Capscrew
23. Handwheel
24. Key
25. Calibration Head
26. Capscrew
27. Wiper
28. Thrust Washer
29. Thrust Bearing
30. Thrust Washer
31. Thrust Bearing
32. Capscrew
33. Seal Pack: Stem - Bonnet
34. Retaining Ring
35. Lockwasher
36. Balance Sleeve
37. External-Sleeve Bushing
38. B/U Ring: External Sl. - Balance Sl.
39. Seal: External Sl. - Balance Sleeve

P3 Product Family

Standard:

- P3E - Bolted Bonnet; 6 000 PSI

Other Options:

- P3E 10k - Bolted Bonnet; 10 000 PSI
- P3E HT - Bolted Bonnet; 3 600 PSI;
High Temperature Service
- C3E - Bolted Bonnet; 3 600 PSI; Inline
- C3E HT - Bolted Bonnet; 3 600 PSI;
High-Temperature Service

chokes
for all applications



THE LEADER IN CHOKE TECHNOLOGY

recycle lines



vent valves



manifold



production



blow down

overboard dumps



level controllers

glycol injection



subsea

water injection



www.masterflo.com
info@masterflo.com
info@masterflo.co.uk