

E P2E High-Temperature Choke 5CB

6 000 psig / Max Cv 27 / Max Bean Size 81

VALVE SPECIFICATIONS ▶

This choke-valve option, suitable for high-temperature applications, uses a hammer-union nut to retain the bonnet and flow trim in the valve body. Standard end connections range in size from 2" to 3".

Valve Model	P2E HT
Body Type	Right Angle
Body Rating	6 000 PSIG (Maximum C.W.P.)
Inlet Connection	see 'Standard End Connections'
Outlet Connection	see 'Standard End Connections'
Bonnet Type	Hammer Union Nut
Body / Bonnet Material	see 'Material Options'
Stem Material	see 'Material Options'
Seal Material	see 'Material Options'
Trim Style	Ported Cage with External Sleeve
Balanced / Unbalanced	Unbalanced
Flow Characteristic	Equal Percentage
Trim Material	see 'Trim Options'
Design Cv	see 'Trim Options'
Leakage Class	Class V (Standard)



TRIM OPTIONS ▶

	Standard Trim Cage & External Sleeve 2 Row / 4 Hole
Material	UNS S17400, Stellite
Application	Liquid, Gas, Multiphase
Cv	27
Turns	11
Travel	1.35"

STANDARD END CONNECTIONS ▶

Connection Size ▶	Standard Dimensions & Estimated Weights											
	2" Nominal				2-1/2" Nominal				3" Nominal			
	'I' or 'O'		Weight		'I' or 'O'		Weight		'I' or 'O'		Weight	
Connection Type ▼	inch	mm	lbs.	kg	inch	mm	lbs.	kg	inch	mm	lbs.	kg
Threaded	4.50	114	82	37	n/a	n/a	n/a	n/a	n/a	n/a	n/a	n/a
ASME 150 RF	7.00	178	92	42	7.25	184	101	46	7.25	184	103	47
ASME 300 RF	7.25	184	96	44	7.50	191	106	48	7.62	194	114	52
ASME 600 RF	7.62	194	100	45	7.88	200	110	50	8.00	203	116	53
ASME 600 RTJ	7.69	195	100	45	7.94	202	110	50	8.06	205	116	53
ASME 900 RF	8.75	222	128	58	8.88	225	149	68	8.75	222	138	63
ASME 900 RTJ	8.81	224	128	58	8.94	227	149	68	8.81	224	138	63
ASME 1500 RF	8.75	222	128	58	8.88	225	149	68	9.38	238	176	80
ASME 1500 RTJ	8.81	224	128	58	8.94	227	149	68	9.44	240	176	80
ASME 2500 RTJ	9.81	249	164	74	10.50	267	191	87	11.50	292	268	122
2 000 API 6B **	7.69	195	100	45	7.94	202	110	50	8.06	205	116	53
3 000 API 6B **	8.81	224	128	58	8.94	227	149	68	8.81	224	138	63
5 000 API 6B **	8.81	224	128	58	8.94	227	149	68	9.44	240	176	80

** Not API monogrammable due to temperature range.

ENVELOPE DIMENSIONS ▶

Dimensions 'A', 'B', and 'C' apply to manually operated chokes and are tabulated below. 'I' (inlet) and 'O' (outlet) dimensions depend on the end connections and are tabulated above. Special dimensions and other end connections are available upon request.

Dimensions		
	inch	mm
A	15.75	400
B	18.00	457
C	21.62	549

Note: "C" is the disassembly clearance.

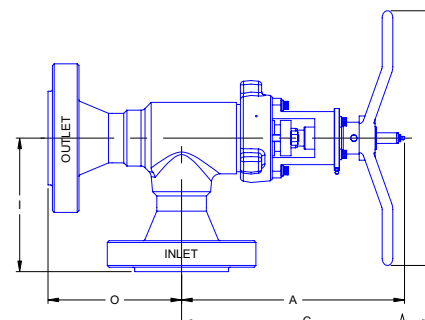

6A-0138

17D-0008

MATERIAL OPTIONS

Temperature Class	Certification Level	API - 6A Material Class Designations						
		AA	BB	CC	DD	EE	FF	HH
PU -20F to 800F	STD / PSL-1	BB	BB	CC	n/a	n/a	n/a	n/a
	PSL-2	BB	BB	CC	n/a	n/a	n/a	n/a
	PSL-3	BB	BB	CC	n/a	n/a	n/a	n/a

	BB-General Service	EE-Sour Service
Body	AISIS 8620	AISI 316 *
Bonnet	ASTM A350 LF2 or AISI 4130	AISI 316
Stem	UNS S17400	UNS S17400
Bolting	ASTM A320 L7M	ASTM A320 L7M
Retaining Sleeve	ASTM A743 CF8M	ASTM A743 CF8M
Seals	SS/Graphoil	SS/Graphoil

Other materials available upon request.

* Not available for API-rated valves.

OTHER VALVE OPTIONS

	Standard	Optional
Calibration Head / Serial Plaque	Aluminum	Stainless Steel
Outlet Sleeve	-	n/a
Body Bleed Port	-	½" NPT, API Autoclave

ACTUATION OPTIONS

Master Flo	Other
Manually Operated	Pneumatic Piston
	Pneumatic Diaphragm

Other actuators available upon request.

PERFORMANCE CHARACTERISTICS

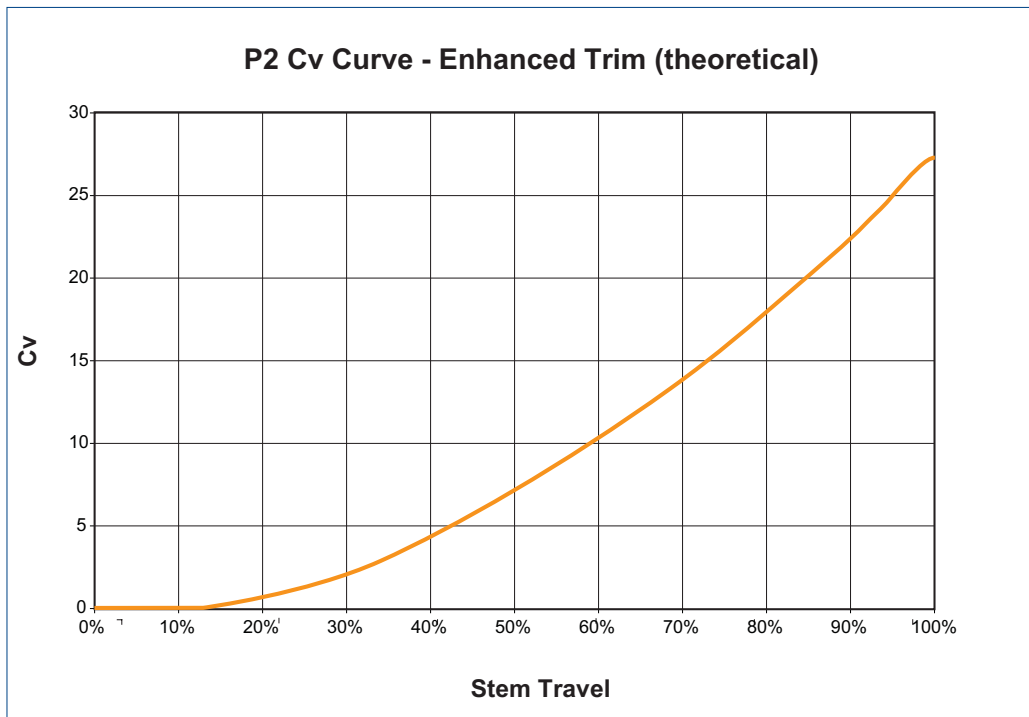

LIQUID PRESSURE RECOVERY FACTOR (FL)

Master Flo's trim geometry has been designed to achieve high F_L numbers. This results in a decreased cavitation potential, lower noise generation, increased flow capacity, and longer trim life. The high F_L numbers of Master Flo's trims have been verified experimentally as per the test procedures of ISA-S75.02-1996.

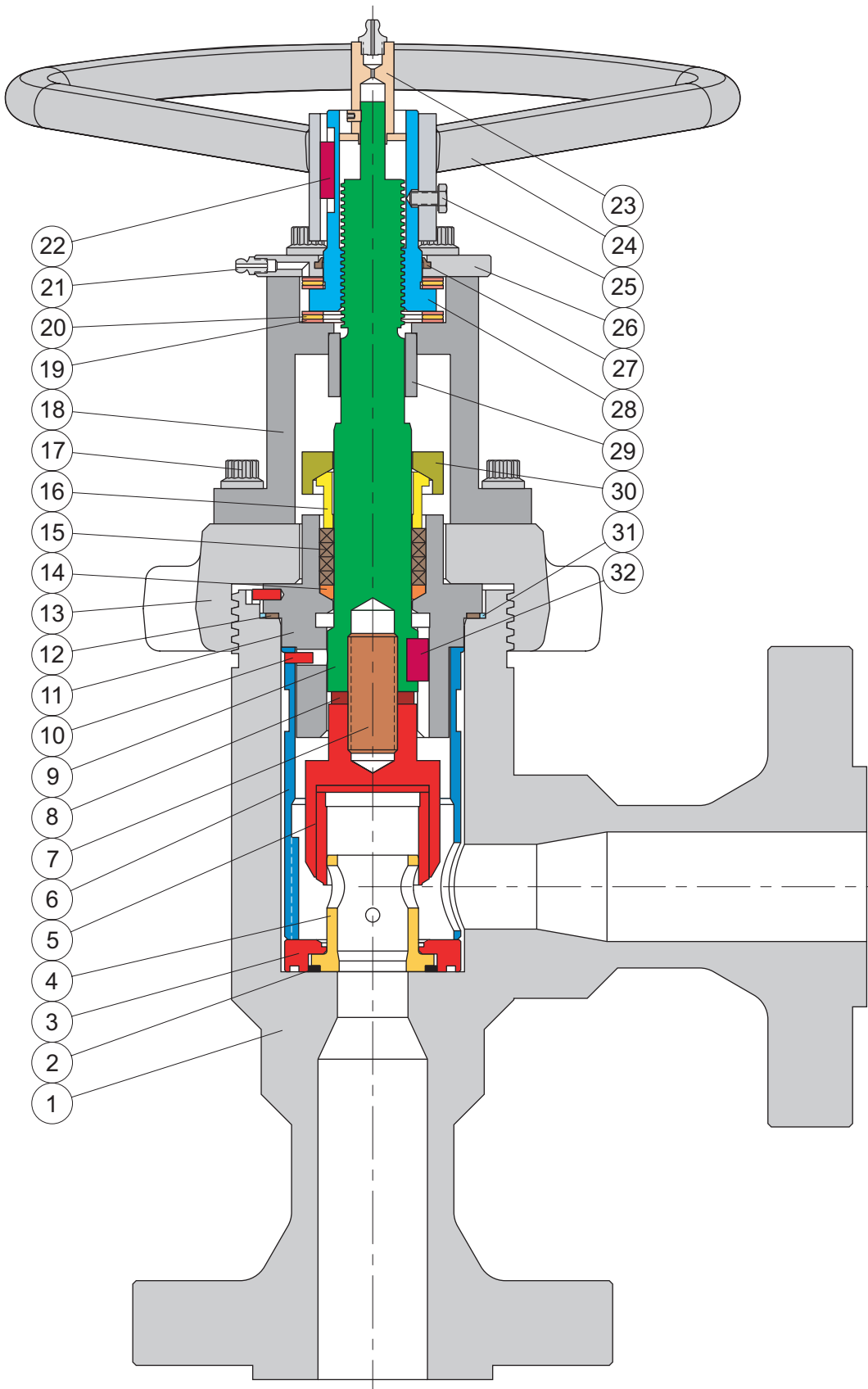

PARTS LIST

- 1. Body
- 2. Seal: Nozzle - Body
- 3. Seat
- 4. Cage
- 5. External Sleeve
- 6. Retaining Sleeve
- 7. Stud
- 8. Lockwasher
- 9. Stem
- 10. Pin
- 11. Bonnet
- 12. Seal: Bonnet - Body
- 13. Bonnet Nut
- 14. Packing Leader
- 15. Packing: Stem - Bonnet
- 16. Packing Follower
- 17. Capscrew
- 18. Yoke
- 19. Thrust Washer
- 20. Thrust Bushing
- 21. Grease Nipple
- 22. Key
- 23. Calibration Head
- 24. Handwheel
- 25. Capscrew
- 26. Cover Plate
- 27. Wiper
- 28. Stem Nut
- 29. Yoke Sleeve
- 30. Packing Gland
- 31. Retaining Ring
- 32. Key
- 33. Nut (not visible)
- 34. Stud (not visible)

P2 Product Family

Standard:

- P2E - Hammer-Union Bonnet; 10 000 PSI

Other Options:

- P2E BB - Bolted Bonnet; 6 000 PSI
- P2E 10k BB - Bolted Bonnet; 10 000 PSI
- **P2E HT - Hammer Union; 6 000 PSI; High-Temperature Service**
- C2E - Hammer Union; 6 000 PSI; Inline
- C2E BB - Bolted Bonnet; 6 000 PSI; Inline
- C2E HT - Hammer Union; 6 000 PSI; Inline; High-Temperature Service

chokes for all applications

recycle lines



manifold



vent valves



production



blow down

glycol injection

overboard dumps



subsea



level controllers

water injection



www.masterflo.com
info@masterflo.com
info@masterflo.co.uk