

E P25E 15k Series-2 Choke



15 000 psig / Max Cv 45 / Max Bean Size 103

VALVE SPECIFICATIONS ▶

Valve Model	P25E BB
Body Type	Right Angle
Body Rating	15 000 PSIG (Maximum C.W.P.)
Inlet Connection	see 'Standard End Connections'
Outlet Connection	see 'Standard End Connections'
Bonnet Type	Bolted
Body / Bonnet Material	see 'Material Options'
Stem Material	see 'Material Options'
Seal Material	see 'Material Options'
Trim Style	Ported Cage with External Sleeve
Balanced / Unbalanced	Unbalanced
Flow Characteristic	Equal Percentage
Trim Material	see 'Trim Options'
Design Cv	see 'Trim Options'
Leakage Class	Class V (Standard)

TRIM OPTIONS ▶

	Standard Trim Cage & External Sleeve 2 Row / 4 Hole
Material	UNS S17400, Stellite, Tungsten Carbide
Application	Liquid, Gas, Multiphase; Abrasive
Cv	45
Turns	12
Travel	1.50"



STANDARD END CONNECTIONS ▶

Connection Size ▶	Standard Dimensions & Estimated Weights											
	2" Nominal				2-1/2" Nominal				3" Nominal			
	'I' or 'O'		Weight		'I' or 'O'		Weight		'I' or 'O'		Weight	
Connection Type ▼	inch	mm	lbs.	kg	inch	mm	lbs.	kg	inch	mm	lbs.	kg
ASME 150 RF	7.75	197	175	79	8.00	203	184	84	8.00	203	186	84
ASME 300 RF	8.00	203	179	81	8.25	210	189	86	8.38	213	197	89
ASME 600 RF	8.38	213	206	94	8.62	219	194	88	8.75	222	258	117
ASME 600 RTJ	8.44	214	206	94	8.69	221	194	88	8.81	224	258	117
ASME 900 RF	9.50	241	218	99	9.62	244	231	105	9.50	241	269	122
ASME 900 RTJ	9.56	243	218	99	9.69	246	231	105	9.56	243	269	122
ASME 1500 RF	9.50	241	218	99	9.62	244	231	105	10.13	257	289	131
ASME 1500 RTJ	9.56	243	218	99	9.69	246	231	105	10.9	259	289	131
ASME 2500 RTJ	n/a	n/a	n/a	n/a	11.25	286	278	126	12.25	311	351	159
2 000 API 6B	8.44	214	206	94	8.69	221	194	88	8.81	224	258	117
3 000 API 6B	9.56	243	218	99	9.69	246	231	105	9.56	243	269	122
5 000 API 6B	9.56	243	218	99	9.69	246	231	105	10.19	259	289	131
10 000 API 6BX	9.56	243	218	99	10.12	257	233	106	10.75	273	293	133
15 000 API 6BX	10.25	260	229	104	10.69	271	255	116	11.25	286	318	144

ENVELOPE DIMENSIONS ▶

Dimensions 'A', 'B', and 'C' apply to manually operated chokes and are tabulated below. 'I' (inlet) and 'O' (outlet) dimensions depend on the end connections and are tabulated above. Special dimensions and other end connections are available upon request.

Dimensions		
	inch	mm
A	17.06	433
B	18.00	457
C	25.31	643

Note: "C" is the disassembly clearance.

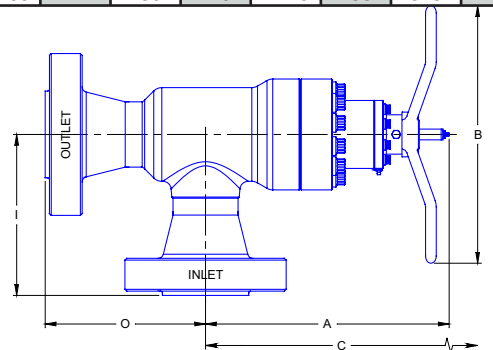

6A-0138

17D-0008

MATERIAL OPTIONS

Temperature Class	Certification Level	API - 6A Material Class Designations						
		AA	BB	CC	DD	EE	FF	HH
PU -20F to 250F	STD / PSL-1	EE	EE	FF	EE	EE	FF	HH
PX -20F to 350F *	PSL-2	EE	EE	FF	EE	EE	FF	HH
	PSL-3	EE	EE	FF	EE	EE	FF	HH
LU -50F to 250F	STD / PSL-1	EE	EE	FF	EE	EE	FF	HH
	PSL-2	EE	EE	FF	EE	EE	FF	HH
	PSL-3	EE	EE	FF	EE	EE	FF	HH

* Not available in Material Class HH.

	EE-Sour Service	FF-Sour Service	HH-Sour Service
Body	AISI 8620	UNS S31803	AISI 8620 / Inconel 625
Bonnet	AISI 4130	AISI 4130 / UNS S31803	AISI 4130 / Inconel 718
Stem	UNS S17400	UNS S17400	Inconel 718
Bolting	ASTM A320 L7M	ASTM A320 L7M	ASTM A320 L7M
Retaining Sleeve	ASTM A743 CF8M	ASTM A743 CF8M	Inconel 625
Seals	Teflon	Teflon	Teflon

Other materials available upon request.

OTHER VALVE OPTIONS

	Standard	Optional
Calibration Head / Serial Plaque	Aluminum	Stainless Steel
Outlet Sleeve	-	Stainless Steel, Tungsten Carbide
Body Bleed Port	-	½" NPT, API Autoclave

Some limitations may apply.

ACTUATION OPTIONS

Master Flo	Other
Manually Operated (Stemlock is optional)	Rotary Electric
Rotary Stepping (Pneumatic)	Pneumatic Piston
Rotary Stepping (Hydraulic)	
FC Hydraulic Piston	

Other actuators available upon request.

PERFORMANCE CHARACTERISTICS

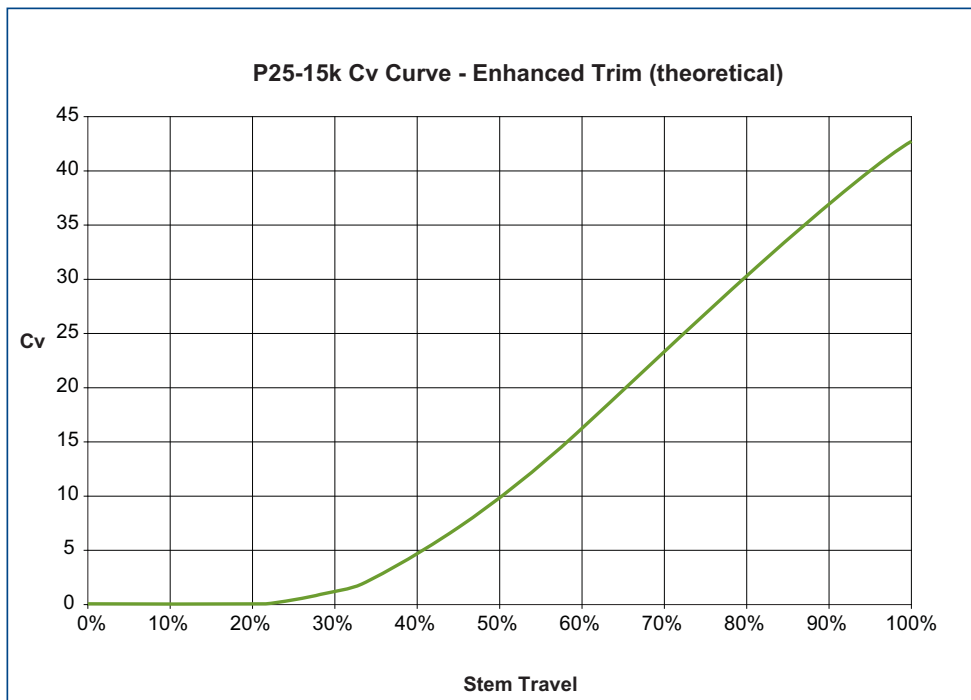

LIQUID PRESSURE RECOVERY FACTOR (FL)

Master Flo's trim geometry has been designed to achieve high F_L numbers. This results in a decreased cavitation potential, lower noise generation, increased flow capacity, and longer trim life. The high F_L numbers of Master Flo's trims have been verified experimentally as per the test procedures of ISA-S75.02-1996.

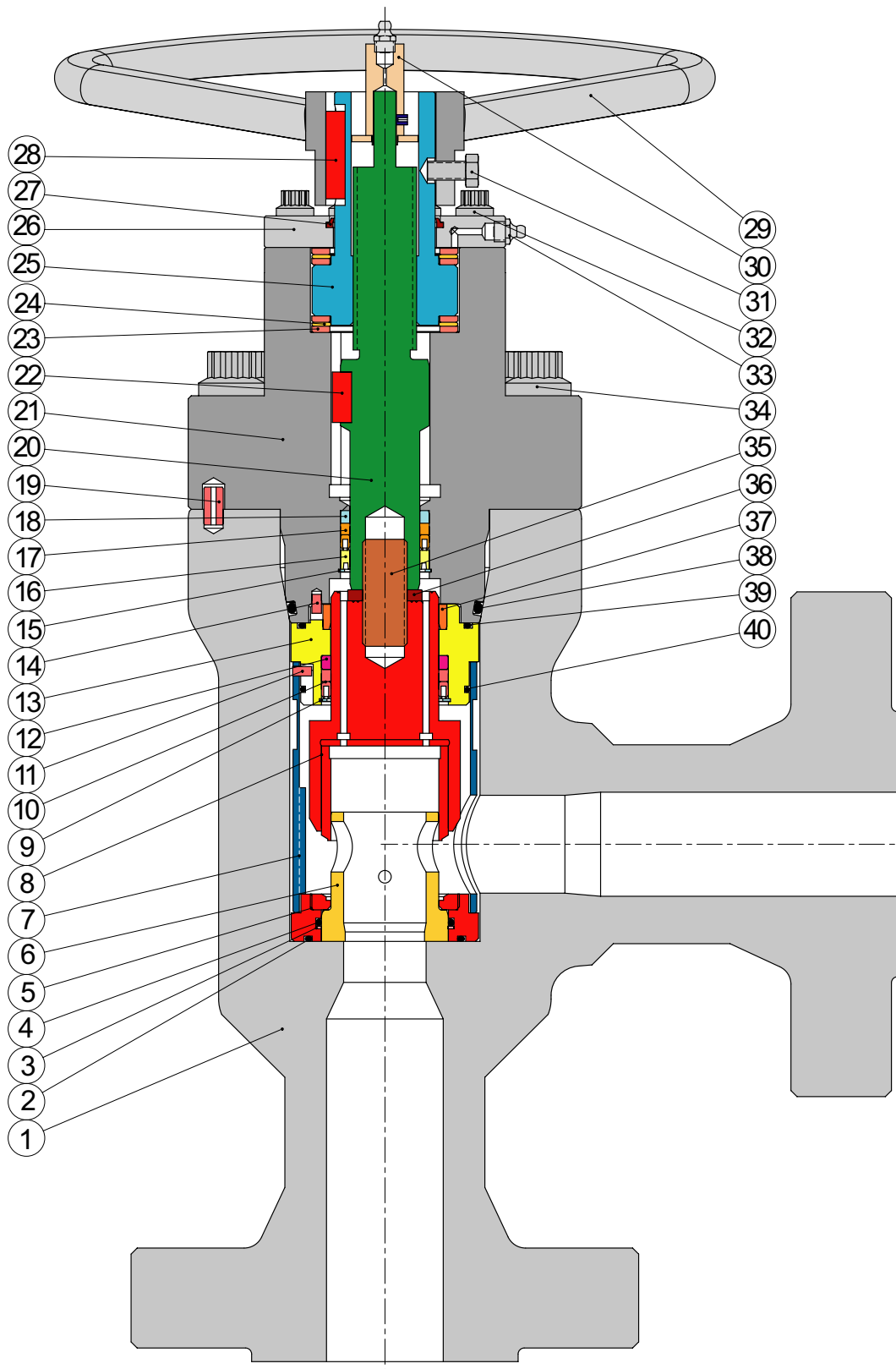

PARTS LIST

1. Body
2. Seal: Seat - Body
3. B/U Ring: Nozzle - Seat
4. Seal: Nozzle - Seat
5. Seat
6. Cage
7. Retaining Sleeve
8. External Sleeve
9. Retaining Ring
10. Seal: Flow Ring - Balance Sleeve
11. Pin
12. Flow-Ring Bushing
13. Balance Sleeve
14. Pin
15. Retaining Ring
16. Stem Bushing
17. Seal: Stem - Bonnet
18. Stem Bushing
19. Spring Pin
20. Stem
21. Bonnet
22. Key
23. Thrust Washer
24. Thrust Bearing
25. Stem Nut
26. Cover Plate
27. Wiper
28. Key
29. Handwheel
30. Calibration Head
31. Capscrew
32. Capscrew
33. Grease Nipple
34. Capscrew
35. Stud
36. Lockwasher
37. Flow-Ring Bushing
38. Seal: Bonnet - Body
39. Seal: Balance Sleeve - Bonnet
40. Seal: Balance Sleeve - Retaining Sleeve

P25 Product Family

Standard:

- P25E - Hammer-Union Bonnet; 5 000 PSI

Other Options:

- P25E BB - Bolted Bonnet; 6 000 PSI
- **P25E 15k - Bolted Bonnet; 15 000 PSI**
- P25E HT - Hammer Union; 5 000 PSI; High-Temperature Service
- C25E - Hammer Union; 3 600 PSI; Inline
- C25E BB - Bolted Bonnet; 3 600 PSI; Inline
- C25E HT - Hammer Union; 3 600 PSI; Inline; High-Temperature Service

chokes for all applications

recycle lines



manifold



vent valves



production



blow down

glycol injection



overboard dumps



level controllers

water injection



subsea