

# E C2E Valve

6 000 psig / Max Cv 27 / Max Bean Size 81

## VALVE SPECIFICATIONS ▶

This control valve uses a hammer-union nut to retain the bonnet and flow trim in the valve body. Standard end connections range in size from 2" to 3".

Valve Model	C2E
Body Type	Inline
Body Rating	6 000 PSIG (Maximum C.W.P.)
Inlet Connection	see 'Standard End Connections'
Outlet Connection	see 'Standard End Connections'
Bonnet Type	Hammer Union Nut
Body / Bonnet Material	see 'Material Options'
Stem Material	see 'Material Options'
Seal Material	see 'Material Options'
Trim Style	Ported Cage with External Sleeve
Balanced / Unbalanced	Semi-Balanced
Flow Characteristic	Equal Percentage
Trim Material	see 'Trim Options'
Design Cv	see 'Trim Options'
Leakage Class	Class V (Standard)

picture not available

## TRIM OPTIONS ▶

	Standard Trim Cage & External Sleeve 2 Row / 4 Hole	Multistage Trim	High-Pressure Multi-stage Trim
Material	UNS S17400, Stellite, Tungsten Carbide	Stellite, Tungsten Carbide	Stellite, Tungsten Carbide
Application	Liquid, Gas, Multiphase; Abrasive	Liquid, Gas, Multiphase	Liquid, Gas, Multiphase
Cv	27	7	6
Turns	11	8	8
Travel	1.35"	1.00"	1.00"

## STANDARD END CONNECTIONS ▶

Connection Size ▶	Standard Dimensions & Estimated Weights							
	2" Nominal				3" Nominal			
	'F'		Weight		'F'		Weight	
Connection Type ▼	inch	mm	lbs.	kg	inch	mm	lbs.	kg
Threaded	11.25	286	87	40	-	-	-	-
ASME 150 RF	10.00	254	93	42	*12.50	*318	101	46
ASME 300 RF	10.50	267	96	44	12.50	318	101	46
ASME 600 RF	11.25	286	99	45	13.25	337	110	50
ASME 600 RTJ	11.38	289	99	45	13.38	340	110	50
ASME 900 RF	14.75	375	127	58	17.38	441	145	66
ASME 900 RTJ	14.88	378	127	58	17.50	445	145	66
ASME 1500 RT	14.75	375	127	58	18.12	460	168	76
ASME 1500 RTJ	14.88	378	127	58	18.25	464	168	76

\* Not a standard ISA face-to-face dimension.

## ENVELOPE DIMENSIONS ▶

Dimensions 'A', 'B', and 'C' apply to manually operated valves and are tabulated below. 'F' (face-to-face) dimension depends on the end connection and is tabulated above. Special dimensions and other end connections are available upon request.

Dimensions		
	inch	mm
A	14.75	375
B	18.00	457
C	20.62	524
D	3.50	89

**Note:** "C" is the disassembly clearance.

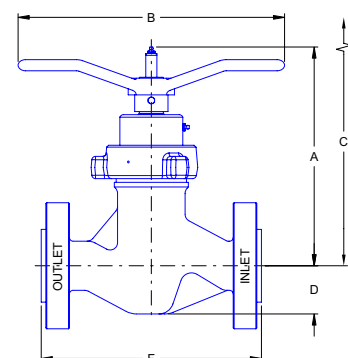

**MATERIAL OPTIONS**

Temperature Class	Certification Level	API - 6A Material Class Designations						
		AA	BB	CC	DD	EE	FF	HH
PU -20F to 250F PX -20F to 350F	STD / PSL-1	BB	BB	FF	EE	EE	FF	n/a
	PSL-2	EE	EE	FF	EE	EE	FF	n/a
	PSL-3	EE	EE	FF	EE	EE	FF	n/a
LU -50F to 250F	STD / PSL-1	EE	EE	FF	EE	EE	FF	n/a
	PSL-2	EE	EE	FF	EE	EE	FF	n/a
	PSL-3	EE	EE	FF	EE	EE	FF	n/a

	BB-General Service	EE-Sour Service	FF-Sour Service
<b>Body</b>	ASTM A352 LCC / ASTM A216 WCB	ASTM A352 LCC / ASTM A216 WCB	ASTM A351 CF8M
<b>Bonnet</b>	ASTM A350 LF2 or AISI 4130	ASTM A350 LF2 or AISI 4130	UNS S31803
<b>Stem</b>	UNS S17400	UNS S17400	UNS S17400
<b>Bolting</b>	AISI 4130	AISI 4130	AISI 4130
<b>Retaining Sleeve</b>	ASTM A743 CF8M	ASTM A743 CF8M	ASTM A743 CF8M
<b>Seals</b>	Buna - N	Viton	Viton

Other materials available upon request.

**OTHER VALVE OPTIONS**

	Standard	Optional
<b>Calibration Head / Serial Plaque</b>	Aluminum	Stainless Steel
<b>Outlet Sleeve</b>	-	n/a
<b>Body Bleed Port</b>	-	n/a

Some limitations may apply.

**ACTUATION OPTIONS**

Master Flo	Other
Manually Operated	Pneumatic Diaphragm
FC Hydraulic Piston	Pneumatic Piston
Pneumatic Piston	

Other actuators available upon request.

**PERFORMANCE CHARACTERISTICS**

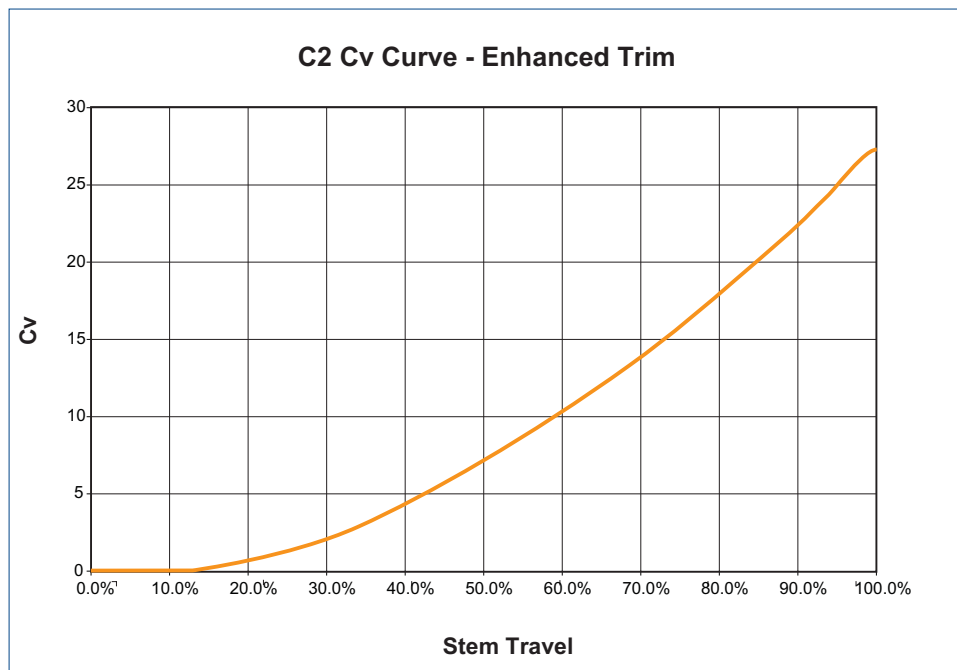

**LIQUID PRESSURE RECOVERY FACTOR (FL)**

Master Flo's trim geometry has been designed to achieve high  $F_L$  numbers. This results in a decreased cavitation potential, lower noise generation, increased flow capacity, and longer trim life. The high  $F_L$  numbers of Master Flo's trims have been verified experimentally as per the test procedures of ISA-S75.02-1996.

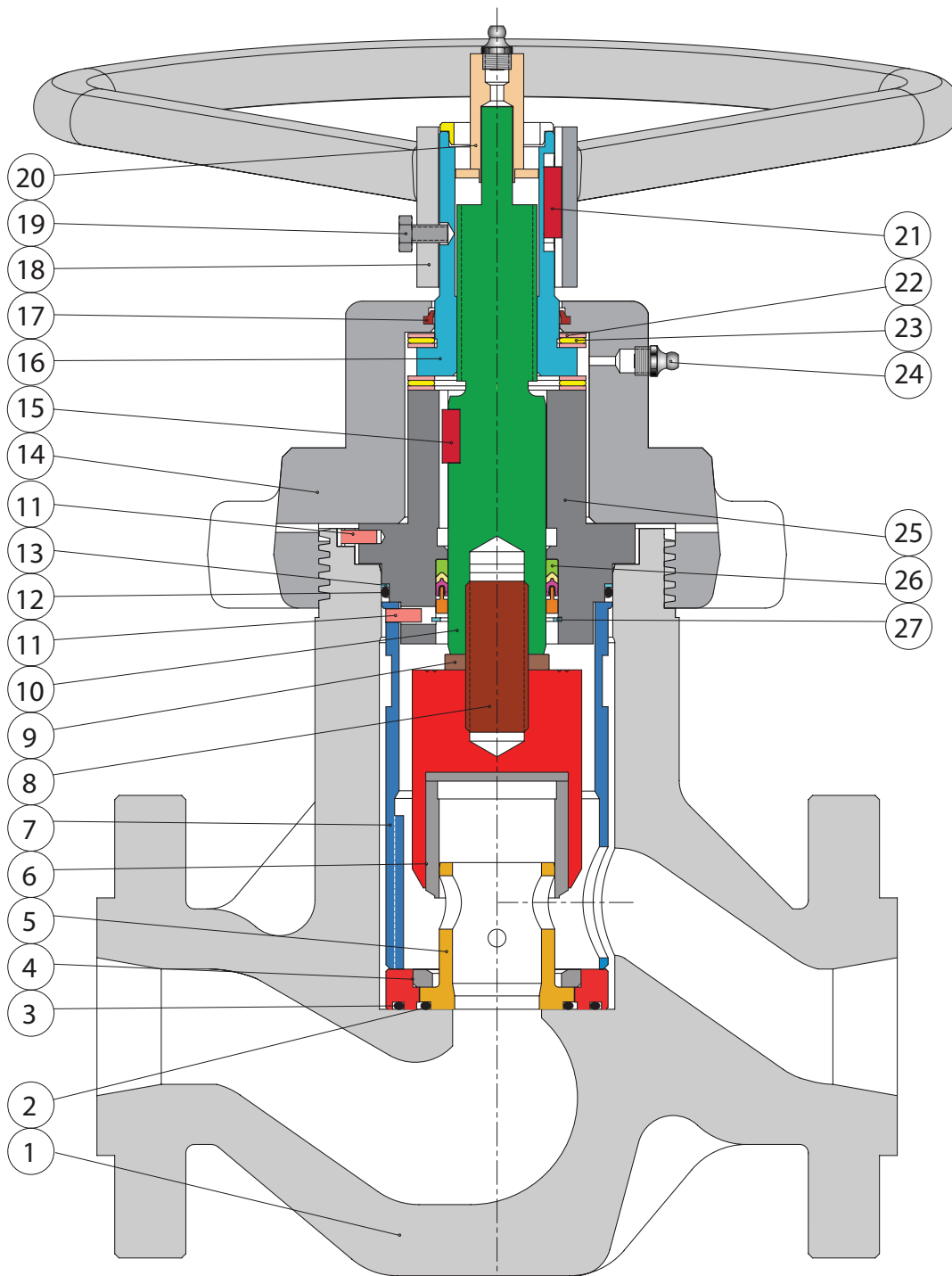

### PARTS LIST

1. Body
2. Seal: Cage - Body
3. Seal: Seat - Body
4. Seat
5. Cage
6. External Sleeve
7. Retaining Sleeve
8. Stud
9. Lockwasher
10. Stem
11. Pin
12. Seal: Bonnet - Body
13. B/U Ring: Bonnet - Body
14. Bonnet Nut
15. Key
16. Stem Nut
17. Wiper
18. Handwheel
19. Capscrew
20. Calibration Head
21. Key
22. Thrust Washer
23. Thrust Bearing
24. Grease Nipple
25. Bonnet
26. Seal Pack: Stem - Bonnet
27. Retaining Ring

### P2 Product Family

#### Standard:

- P2E - Hammer-Union Bonnet; 10 000 PSI

#### Other Options:

- P2E BB - Bolted Bonnet; 6 000 PSI
- P2E 10k BB - Bolted Bonnet; 10 000 PSI
- P2E HT - Hammer Union; 6 000 PSI; High-Temperature Service
- C2E - Hammer Union; 6 000 PSI; Inline
- C2E BB - Bolted Bonnet; 6 000 PSI; Inline
- C2E HT - Hammer Union; 6 000 PSI; Inline; High-Temperature Service

**chokes**  
for all applications

recycle lines



vent valves



manifold



production



blow down

glycol injection

overboard dumps



subsea



level controllers

water injection

