

# E C25E High-Temperature Valve

3 600 psig / Max Cv 45 / Max Bean Size 103



## VALVE SPECIFICATIONS

This control-valve option, suitable for high-temperature applications, uses a hammer-union nut to retain the bonnet and flow trim in the valve body. Standard end connections range in size from 2" to 3".

Valve Model	C25E
Body Type	Inline
Body Rating	3 600 PSIG (Maximum C.W.P.)
Inlet Connection	see 'Standard End Connections'
Outlet Connection	see 'Standard End Connections'
Bonnet Type	Hammer-Union Nut
Body / Bonnet Material	see 'Material Options'
Stem Material	see 'Material Options'
Seal Material	see 'Material Options'
Trim Style	Ported Cage with External Sleeve
Balanced / Unbalanced	Semi-Balanced
Flow Characteristic	Equal Percentage
Trim Material	see 'Trim Options'
Design Cv	see 'Trim Options'
Leakage Class	Class V (Standard)

photo not available

## TRIM OPTIONS

	<b>Standard Trim Cage &amp; External Sleeve 2 Row / 4 Hole</b>
Material	UNS S17400, Stellite, Tungsten Carbide *
Application	Liquid, Gas, Multiphase; Clean
Cv	45
Turns	12
Travel	1.50"

\* Cage only.

## STANDARD END CONNECTIONS

Connection Size ▶	Standard Dimensions & Estimated Weights							
	2" Nominal				3" Nominal			
	'F'		Weight		'F'		Weight	
Connection Type ▼	inch	mm	lbs.	kg	inch	mm	lbs.	kg
Threaded	11.25	286	87	40	-	-	-	-
ASME 150 RF	10.00	254	100	45	*12.50	*318	119	54
ASME 300 RF	10.50	267	104	47	12.50	318	119	54
ASME 600 RF	11.25	286	110	50	13.25	337	125	57
ASME 600 RTJ	11.38	289	110	50	13.38	340	125	57
ASME 900 RF	14.75	375	149	66	17.38	441	164	74
ASME 900 RTJ	14.88	378	149	66	17.50	445	164	74
ASME 1500 RT	14.75	375	149	66	18.12	460	196	89
ASME 1500 RTJ	14.88	378	149	66	18.25	464	196	89

\* Not a standard ISA face-to-face dimension.

## ENVELOPE DIMENSIONS

Dimensions 'A', 'B', and 'C' apply to manually operated valves and are tabulated below. 'F' (face-to-face) dimension depends on the end connection and is tabulated above. Special dimensions and other end connections are available upon request.

Dimensions		
	inch	mm
A	17.62	448
B	18.00	457
C	23.62	600
D	3.75	95

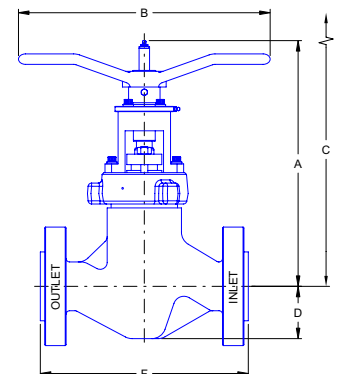

Note: "C" is the disassembly clearance.



**MATERIAL OPTIONS**

Temperature Class	Certification Level	API - 6A Material Class Designations						
		AA	BB	CC	DD	EE	FF	HH
-20F to 750F	STD / PSL-1	BB	BB	CC	n/a	n/a	n/a	n/a
	PSL-2	BB	BB	CC	n/a	n/a	n/a	n/a
	PSL-3	BB	BB	CC	n/a	n/a	n/a	n/a

	BB-General Service	CC-General Service
Body	ASTM A352 LCC / ASTM A216 WCB	ASTM A351 CF8M
Bonnet	ASTM A350 LF2 or AISI 4130	AISI 316
Stem	UNS S17400	UNS S17400
Bonnet Nut	AISI 4130	AISI 4130
Retaining Sleeve	ASTM A743 CF8M	ASTM A743 CF8M
Seals	SS / Graphoil	SS / Graphoil

Other materials available upon request.

**OTHER VALVE OPTIONS**

	Standard	Optional
Calibration Head / Serial Plaque	Aluminum	Stainless Steel
Outlet Sleeve	-	n/a
Body Bleed Port	-	n/a

Some limitations may apply.

**ACTUATION OPTIONS**

Master Flo	Other
Manually Operated	Pneumatic Piston

Other actuators available upon request.

**PERFORMANCE CHARACTERISTICS**

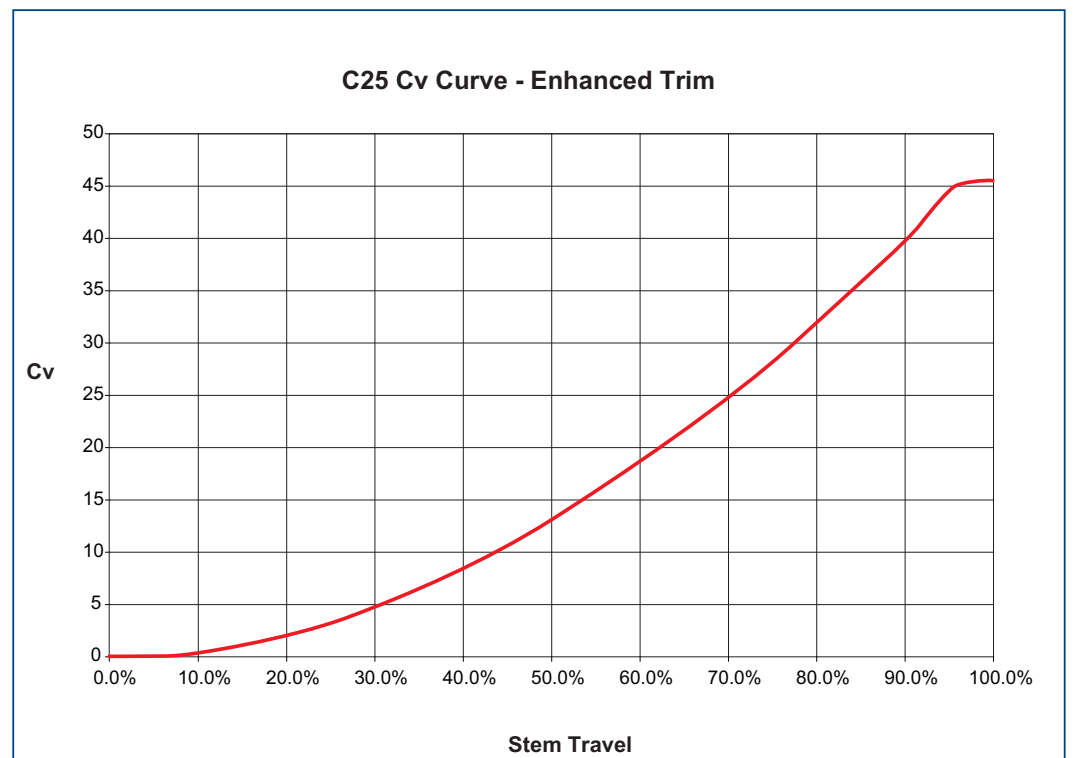

**LIQUID PRESSURE RECOVERY FACTOR (FL)**

Master Flo's trim geometry has been designed to achieve high  $F_L$  numbers. This results in a decreased cavitation potential, lower noise generation, increased flow capacity, and longer trim life. The high  $F_L$  numbers of Master Flo's trims have been verified experimentally as per the test procedures of ISA-S75.02-1996.

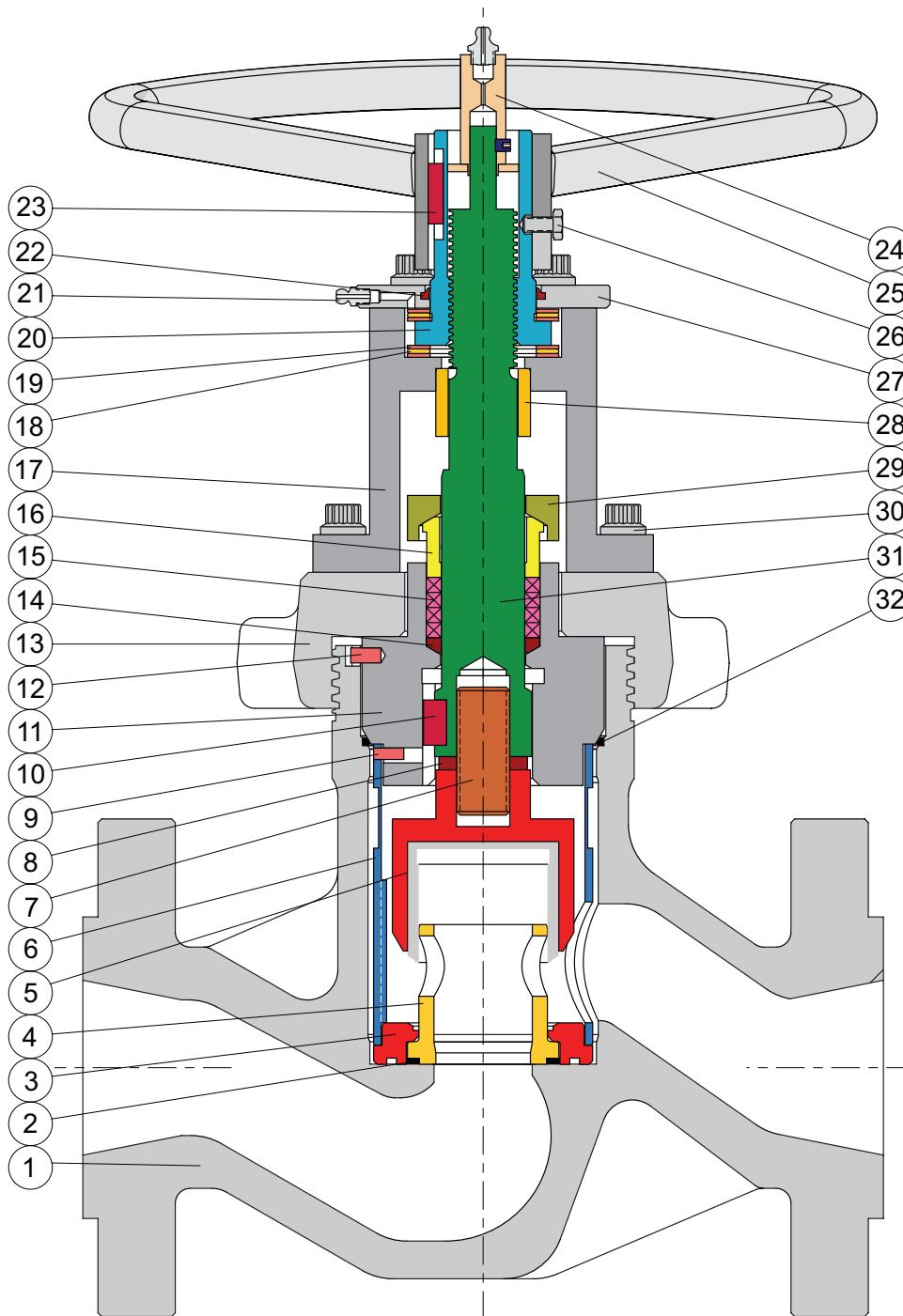

### PARTS LIST

- 1. Body
- 2. Seal: Nozzle/Seat - Body
- 3. Seat
- 4. Cage
- 5. External Sleeve
- 6. Retaining Sleeve
- 7. Stud
- 8. Lockwasher
- 9. Pin
- 10. Key
- 11. Bonnet
- 12. Pin
- 13. Bonnet Nut
- 14. Packing Leader
- 15. Packing
- 16. Packing Follower
- 17. Yoke
- 18. Thrust Bearing
- 19. Thrust Washer
- 20. Stem Nut
- 21. Grease Nipple
- 22. Wiper
- 23. Key
- 24. Calibration Head
- 25. Handwheel
- 26. Capscrew
- 27. Cover Plate
- 28. Yoke Sleeve
- 29. Packing Gland
- 30. Capscrew
- 31. Stem
- 32. Metal Bonnet Seal
- 33. Nut (not visible)
- 34. Stud (not visible)

### P25 Product Family

#### Standard:

- P2E - Hammer-Union Bonnet; 5 000 PSI

#### Other Options:

- P25E BB - Bolted Bonnet; 6 000 PSI
- P25E 15k - Bolted Bonnet; 15 000 PSI
- P25E HT - Hammer Union; 5 000 PSI; High-Temperature Service
- C25E - Hammer Union; 3 600 PSI; Inline
- C25E BB - Bolted Bonnet; 3 600 PSI; Inline
- C25E HT - Hammer Union; 3 600 PSI; Inline; High-Temperature Service

## chokes for all applications

recycle lines



vent valves



manifold



production



blow down

glycol injection

overboard dumps



subsea



level controllers

water injection



[www.masterflo.com](http://www.masterflo.com)  
[info@masterflo.com](mailto:info@masterflo.com)  
[info@masterflo.co.uk](mailto:info@masterflo.co.uk)