

KSB MIL

CONTROL VALVES *for* PROCESS INDUSTRIES

- *Controls*
- *Protects*
- *Performs*



ENGINEERED
PRODUCTS
& SERVICES

E.P.&S.

Your Valve Specialist in Africa



Distributor in Western and Central Africa
for KSB MIL Controls Limited



E.P.&S. and KSB MIL

Introduction

E.P.&S. was established in 2009 and over the years has become Your Valve Specialist in Africa. We specialize in offering tailored valve solutions including fast track or standard lead times – and cater from large valve packages to single valve requirements.

We are specialist valve suppliers of a diverse range of valves including Manual & Actuated On/Off Valves (including Emergency Shutdown Valves, Blow Down Valves & Actuated Valves), Control Valves, API 6A Wellhead Valves & Control Panels, Choke Valves, Rupture Disks & Tank Protection Equipment. We can also supply a full range of accessories (actuators, positioners, solenoid valves, gauges, fittings) in support of such equipment, and are able to offer tailor-made solutions for the most challenging applications.

Our customer base is extremely diverse and includes oil and gas (production, refining, storage, distribution), chemical, food and energy companies. Our presence extends from the end users to integrators and integrators as well.

E.P.&S. is your distributor in Angola, Cameroon, Chad, Congo, Equatorial Guinea, Gabon, Ghana, Guinea Conakry, Ivory Coast, Niger, Senegal, we can offer locally-based technical and commercial support to our customers.

Our reputation rests not only on technical expertise when managing solutions, local knowledge and the supply of quality products, but also on diversity of sourcing, which enables us to meet our customers' specific needs and urgency.

KSB MIL Controls Limited, a subsidiary of **KSB SE & Co. KGaA**, takes the **KSB** group's promise of providing right solutions in fluid control to our customers with the same vigor and intent. **KSB MIL's** control valves adds power and performance necessary for some of the most stringent applications in the most expensive and challenging processes worldwide to ensure successful operation throughout.

KSB MIL Controls Limited (originally established as **Masoneilan Valves India Limited**) started its operations in India during early 1980's by manufacturing Control valves with the solid foundation of the then world's best technology in Control Valves.

Together with a strong R&D, state-of-the-art production & testing facilities, experienced work force and loyal customer base, today **KSB MIL** is a name synonymous with critical control valves for process industries worldwide. With a large installed base of more than two hundred thousand control valves, **KSB MIL** has a marked presence in power stations, oil refining (upstream & downstream), petrochemical and fertilizer plants.



MIL 21000 / 70000

Heavy Post Guided Single Seated Control Valves



Micro-flow high pressure drop plug and seat construction with extra guiding



Double stage low noise/ anti-cavitation trim design for severe service



Committed to an emission free world. Bellows sealed valves for zero gland leakage



Typical MIL 70000 Angle body construction

Applications

- Chemical industry
- Gas pipelines
- Nuclear power stations
- Waste water treatment plants
- Fossil-fuelled power stations
- Paper industry / pulp industry
- Petrochemical industry
- Refinery
- Pharmaceutical industry
- Hot-water supply

Construction

- Top-guided single-seated control valve
- Straight-way pattern with horizontal seat
- PTFE gland packing $\leq 180\text{ }^{\circ}\text{C}$
- Graphite gland packing $> 180\text{ }^{\circ}\text{C}$
- Parabolic plug
- Standard bonnet: temperature range $-29\text{ }^{\circ}\text{C}$ to $427\text{ }^{\circ}\text{C}$
- Leakage class IV to ANSI FCI 70.2

Challenging Performance Limits

- Precise control over wide range of flow

Design Features

- Heavy top guiding (shank guiding)
- Tight shut off capability
- Customized valve trim to meet emerging demands

Optional Characters

- Steam jacketing
- Clamped seat ring
- Extended bonnet design

Field Proven Material

- High Performance material for better longevity

Easy Maintenance

- Fewer internal trim parts
- Quick change trim

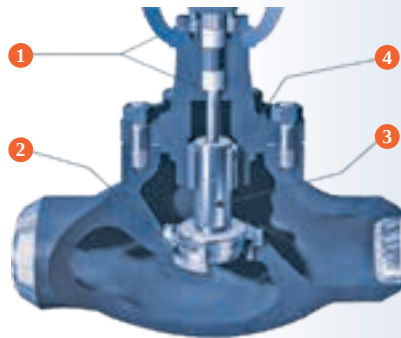

1 Packing box 2 Seat ring
3 Plug stem sub-assembly 4 Guide bush

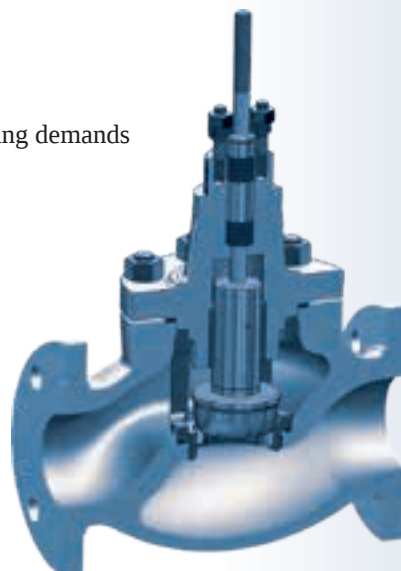

Standard sizes & rating

1/2" to 10": ASME 150# to ASME 2500#

Seat leakage class (as per FCI 70.2)

Standard: Class IV

Optional: Class V & Class VI

Product benefits

- Versatile through a number of designs with different features for handling a wide variety of process applications
- Rugged, heavy plug shank guiding ensures plug stability even in high-pressure service
- Easy to service: The valve trim can be dismantled without any special tools by unscrewing the bonnet bolts

MIL 27000

Compact Globe Control Valves



Standard sizes & rating

½" to 4": ASME 150# to ASME 300#

Seat leakage class (as per FCI 70.2)

Standard: Class IV

Optional: Class V & Class VI

Product benefits

- Compact and light weight construction
- Shank guiding
- Reduced capacity
- Field reversible actuator
- Optional handwheel
- Tight shut-off

The MIL 27000 series compact globe control valves are designed with built-in versatility making them the most widely used control valve well suited to handle a wide variety of process applications.

The single ported shank guided valve with a very unique compact construction makes it the most preferred choice for every industrial segment.

Applications

- With moderate pressure drops
- Used for fluids containing small particulate presence
- Suitable for handling viscous fluids in refineries and petrochemicals
- Pharmaceutical, chemical and bio-medical industries

Compact and Lightweight Construction

Unique compact design, makes the mounting of the valves possible in cramped locations like pharmaceutical plants where mounting space is a constraint.

Shank Guiding

Rugged, shank guiding provides support to ensure plug stability.

Reduced Capacity

In addition to full area trim, reduced trim options are also available to provide a wider flow range capability.

Trim Type

Standard construction offers a threaded seat ring.

Contoured plugs are available with equal percentage or linear characteristics.

Field-reversible Actuator

The air failure action of the actuator can be reversed at site with the usage of minimal spare parts.

Optional Handwheel

Compact top mounted handwheel is an add-on feature for manual operation.

Tight Shut-off

Class IV leakage as per FCI 70.2 is standard.

Optional construction meets Class V & VI seat leakage rates as per FCI 70.2.

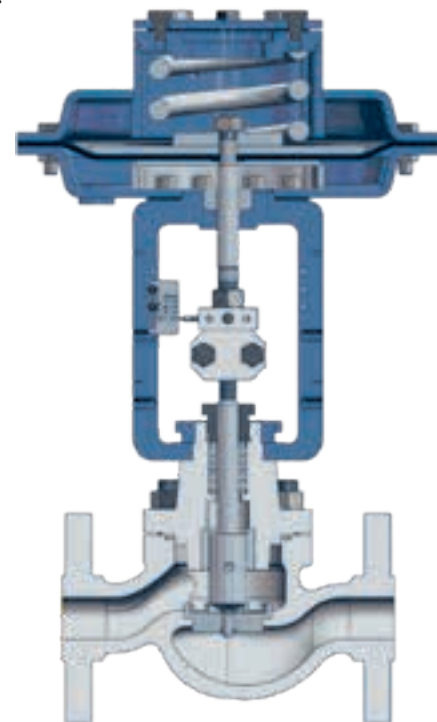

MIL 29000

Micropak Micro Flow Control Valves

Designed specifically for microflow applications, the MIL 29000 series Micropak provides excellent throttling control performance with a wide range of options and capabilities.

Design optimization has also resulted in an extremely integrated and compact assembly. Rugged valve plug support is provided along the entire stroke length using an integrated plug guide and seat ring. This ensures excellent plug stability and control even under high pressure drop conditions. Micropak's simple top-entry body construction includes an integrated body and bonnet design, which allows easy access and removal of the quick change trim.

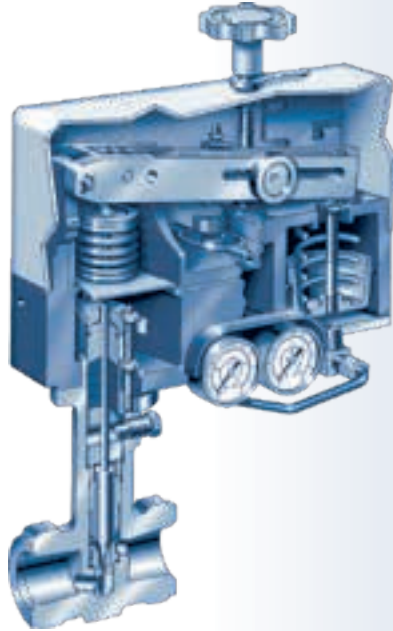

Applications

- Accurate control in low flow applications
- Spray water control in lower capacity power plants
- Chemical and pharmaceutical plants
- Refinery & petrochemical complexes

Adjustable Cv

The rated Cv of the Micropak valve can be adjusted at site to suit the actual operating conditions by setting the knob provided in the actuator. This feature facilitates the user to tailor the control valve to the exact site conditions, avoiding any oversizing in flow capacity and can also help in rationalizing minor mistakes in estimating the process conditions.

Compact and Field-reversible Actuator

The force amplifying technology together with the rolling diaphragm design makes the Micropak design extremely compact. The actuator action also can be easily reversed at site by just relocating the pivot pins.

Versatile Trim Options

Eight plugs and five seat rings are used to make up the ten available plug and seat ring combinations thereby a total of 70 Cvs can easily be made starting from 0.0018 to 3.70. The integral liner and seat ring also reduces components and simplifies assembly and disassembly.

Multi-stage, Axial-flow, High Resistance Trim

Micropak is also available with an optional high pressure liquid letdown anti-cavitation trim solution. This unique design is based on the principle of multi-step high resistance axial-flow. The multistage design of this valve prevents cavitation by directing the fluid through a series of 3-dimensional, high impedance pressure reduction areas or stages. Pressure reduction occurs along the length of the plug through a series of throttling stages, designed to divide the total drop between the trim steps thereby maintaining constant velocity of flow.



Standard sizes & rating

½" to 1": ASME 150# to ASME 1500#

Seat leakage class (as per FCI 70.2)

Standard: Class IV

Optional: Class V

Product benefits

- Adjustable Cv
- Compact & field-reversible actuator
- Versatile trim options
- Multi-stage, axial-flow, high resistance trim

MIL 34000

Eccentric Rotary Plug Valves



Standard sizes & rating

2" to 20": ASME 150# to ASME 600#
DN 25 to DN 500

Seat leakage class (as per FCI 70.2)

Metal to Metal seat: Class IV
PTFE seal: Class VI

Product benefits

- Compact design with high rangeability and C_v
- Self aligning eccentric rotating plug
- Requires less actuator torque
- Reduced trim options available

The eccentric rotary plug valves are commonly used to control slurries or fluids having high particle content. The side entry seat with a retainer, facilitates easy maintenance and the trims face lower wear and tear with a contact-free operation, except in the fully closed condition. MIL 34000 series comes in various configurations including reduced ports for lower flows.

Applications

- Refinery / Oil & gas
- Chemical and fertilizer industries
- Water and steam utility applications
- Clean / dirty corrosive liquids and gases, erosive and abrasive slurries

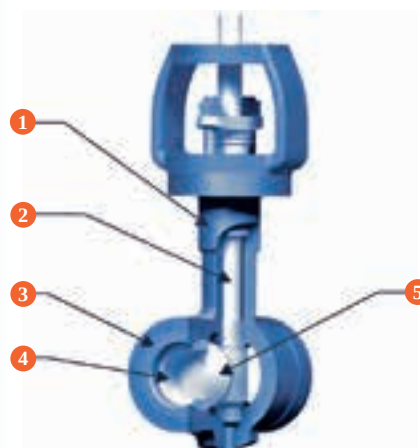

1 Body 2 Shaft 3 Retainer 4 Seat 5 Plug



Eccentric rotary plug valve with rack and pinion actuator



Electrical actuated eccentric rotary plug valve with low noise pak



Diaphragm actuated eccentric rotary plug valve with linkage assembly

Materials

- Body: WCB carbon steel / 316 stainless steel (SS)
- Plug: Stainless Steel, Nickel-plated & Specials on request
- Shaft: Hardened 17-4 PH stainless steel
- Seat: Stainless Steel / PTFE
- Gland / Gland Flange: Stainless Steel

Flow Direction

- Flow to open (inlet from convex side of the plug): for clean liquids, gases, and steam
- Flow to close (inlet from backside of the plug): for erosive and slurry service

Actuator options

- Diaphragm / Electrical / Hydraulic actuators
- Single / double acting rack & pinion actuators
- Single / double acting scotch yoke actuators

MIL 41000 / 71000

Heavy Duty Cage Guided Control Valves

Hallmarks of exceptional service requirements of control valves are four fold: high pressure drop capability, high capacity, tight shutoff and high temperature capability. MIL 41000 series exhibits these characteristics in all valve sizes.

The rugged cage guiding, optional pressure balancing and a host of custom-engineered trim designs make these valves suitable for higher pressure drops and other severe applications, where conventionally designed control valves fail to perform satisfactorily.



Typical MIL 71000
Angle body
construction



MIL 41200/41300
with self-energised
seals for tight shut-off



MIL 41100 / 41700
Unbalanced Trim
combine the dual
advantage of cage
guiding and single seat
leak tightness



MIL 41400
(Pilot plug) Valves for
high temperature tight
shut-off applications



Applications

Utility / Captive Power Plants

- Feed water regulation
- Condensate pump recirculation
- Spray water control and block
- Deaerator pegging steam control
- Soot blower pressure reduction
- Heater drain, ...

Hydrocarbon Processing

- Compressor anti-surge
- Gas gathering and metering stations
- Make-up hydrogen & hydrogen quench
- Cold & hot recycle gas control
- Reactor feed & stripping steam
- Reformed gas vent, hydrocarbons to flare, ...

Higher Allowable Pressure Drops

41000 series control valves provide exceptional and dependable performance over a wide range of pressure drops typical of severe services. Just as important, it handles a vast majority of all shut-off pressures with standard pneumatic spring/diaphragm actuators.

Greater Capacity with Low Recovery

Rated capacity for each 41000 series valve is at top levels established for contemporary cage guided valves. These unusually high capacities are attained with minimum pressure recovery, as indicated by the high critical flow factors, which minimises possibility of cavitation in liquid service.

High Performance Material as Standard

Without exception, the material specified as standard for 41000 series valves have been tested and selected to provide trouble free operation in services with high pressures and extreme temperatures. The superior trim material employed ensures durability of the valve for any severe application.

Simple, High Performance Trim Design

Every valve is available with standard and reduced Cv cages. For balanced design, common plug and seat result in reduced spare parts inventory. For applications where cavitation or high noise is anticipated, standard cage is replaced with multi-hole cage. Clamped seat and cage facilitate easy trim removal and valve maintenance.



Standard sizes & rating

½" to 36": ASME 150# to ASME 4500#

Seat leakage class (as per FCI 70.2)

Standard: Class III et Class IV
Optional: Class V

Product benefits

- High allowable pressure drops
- High capacity with low pressure recovery
- Standardised high performance material
- Clamped Seal ring to facilitate easy removal
- Tight shut-off options
- Anti-cavitation / low noise trims
- Cryogenic applications
- Optional angle body (MIL 71000)

MIL 33000

High Performance Butterfly Valves



Standard sizes & rating

2" to 56": ASME 150# to ASME 2500#
DN 560 to DN 1400

Seat leakage class (as per FCI 70.2)

Metal to Metal seat: Class II, III, IV & V
PTFE / Laminated seal: Class VI

Product benefits

- Excellent flow control and rangeability
- Disc design for minimum dynamic torque
- Low maintenance
- Metallic & Soft seat options

KSB MIL 33000 series Double & Triple offset butterfly valves are considered as High Performance Butterfly valves.

Double offset Butterfly valves are mostly used in industries for control applications where seat leakage requirements are not critical as valves will mostly be in open position ie; in the controllable range between 20% to 80%. Triple Offset Butterfly valves are mostly used in Isolation applications & stringent shut off requirements using Graphite/ PTFE with metallic laminated or Solid metallic seals which ensure better sealing even at high temperature or erosive services. These valves are designed in compliance to API 609, ASME B 16.34 or EN 593 & Tested in accordance to FCI 70.2, API 598, etc.

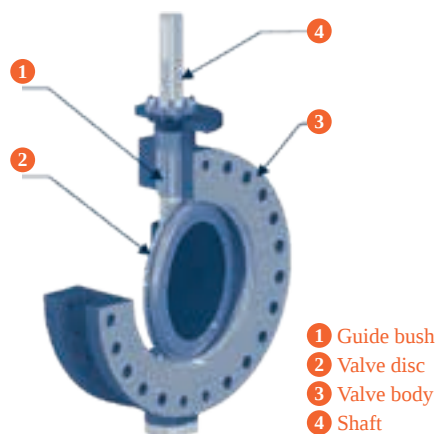

Double flanged double offset butterfly control valve



Butt weld end high pressure butterfly control valve



Wafer type double offset butterfly control valve



Lugged type triple offset butterfly control valve

Applications

- Refinery / Oil & gas
- Chemical and fertilizer industries
- Power stations
- Water and steam applications
- Pulp and paper industries

Additional Design features includes

- Fire safe Design with Primary soft seat & secondary metal seat in accordance to API 607 or ISO 10497. KSB MIL 33000 series soft seated Lugged wafer type Butterfly valves are Fire safe tested & certified by TPI in accordance with API 607. Metallic or laminated seals are considered as inherently Fire safe.
- Fugitive emission testing in accordance to ISO 15848-1.
- Cryogenic testing in accordance to BS 6364 for valve with long extended bonnet with Sealing's complying for cryogenic low temperature services.

MIL 35500

V Notch Segmented Ball Control Valves

MIL 35000 V-Notched segmental ball valves are designed for on/off and throttling applications. These valves have an unrestricted straight through flow design, and provide high capacity for gas, steam, fibrous slurries, or liquids.

This Series is designed with a splined shaft valve body that matches with a variety of actuators to form a dependable high performance control valve ideal for many applications in various processing industries. These valves are designed to overcome the problems of harsh, particle entrained processes, and they also provide accurate, reliable control in a broad range of applications, such as chemical, power and petroleum.

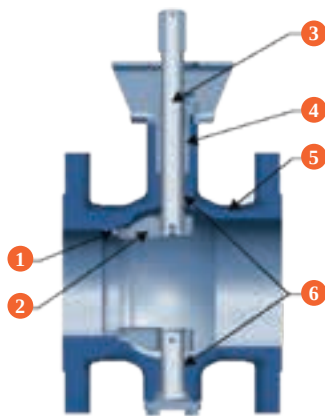

1 Seat 2 Ball 3 Stem 4 Gland packing 5 Body 6 Bearing area



With scotch yoke spring return actuator



With diaphragm actuator



With pneumatic cylinder actuator (link type)

Applications

- Paper and pulp industry: Fibrous media
- Petroleum refineries: Crude oil, naphtha, bitumen, HCO; media containing solids
- Chemical and fertilizer industries: Molten plastics, media containing solids
- Mining Industries: Ore extraction (abrasive and corrosive slurries)
- Sewage treatment plants: Clean/dirty corrosive liquids and gases, erosive and abrasive slurries

Design

- "Single-Piece" body design for minimal potential leak path
- Spring loaded seat ensures proper sealing at low differential pressure
- No-threaded trim parts used
This makes assembly and disassembly of trims at site easy
- Self-aligning segmented ball is facilitated by special shaft and pin design
- Excellent shearing action in fibrous fluid mediums
- Gland packing with anti-extrusion ring prevent the potential leakage of medium to atmosphere
- Blow-out proof stem for higher integrity and safety of the equipment



Standard sizes & rating

1" to 12": ASME 150# to ASME 300#

Seat leakage class (as per FCI 70.2)

Standard: Class IV for Metal seat
& Class VI for Soft seat valves

Product benefits

- Excellent flow control:
Provides a close equal percentage characteristics anti-cavitation trim/ ball optionally available
- High capacity capacity:
Unrestricted straight through flow design provides a greater capacity
- Smooth valve operation:
Precision machined parts and seal designs allow smooth, precise movement of the ball
- Low and high temperature capability:
Many construction materials and close tolerances give MIL 35000 valve design the versatility to be used for applications over a wide temperature range

MIL 78000

Multi-stage Anti-cavitation and Low Noise Control Valves



Standard sizes & rating
½" to 6": ASME 150# to ASME 2500#

Seat leakage class (as per FCI 70.2)
Standard: Class IV & V
Optional: Class VI

- Multi-step axial flow high resistance trim
- Anti-clog design with separable liner/spacer
- High allowable pressure drops with low pressure recovery
- Adiabatic flow with friction
- Standardised high performance material
- Expanding gas trims available
- Soft seated options

MIL 91000

Multi-stage Multi-path Axial Flow Control Valves



Standard sizes & rating
¾" to 20": ASME 150# to ASME 4500#

Seat leakage class (as per FCI 70.2)
Standard: Class V
Optional: Class VI

- Tortuous flow path with high impedance for energy absorption
- Limits trim velocity
- Varying and expanding flow path
- Pressure recovery factor as high as 0.9999
- As many as 40 pressure dropping stages
- Dynamically stable, flow tending to open design
- Modified equal % characteristics with 100:1 rangeability

MIL 10000

Double Ported Top & Bottom Guided Control Valves



Standard sizes & rating
¾" to 16": ASME 150# to 1500#

Seat leakage class (as per FCI 70.2)
Standard: Class II
Optional: Class III & Class VI

- Double ported top & bottom guided control valves
- High allowable pressure drop
- High capacity with low pressure recovery
- Invertible body and plug
- Large flow area suitable for viscous flow

MIL 22000

Bellows Sealed Valves for Critical Service



Standard sizes & rating
¼" to 4": ASME 150# to 2500#

Seat leakage class
< 1x10⁻⁵ mbar lt/sec across seat

- Seal welded bellows sealed valves
- Mountable with pneumatic or electrical actuators
- High cyclic life special bellows
- Secondary packing with leakoff connection
- In built over - travel & antirotation protection
- Colmonoy coated seats

MIL 25000

Self-draining Compact Globe Control Valves



Standard sizes & rating
1": ASME 150# to 300#

Seat leakage class (as per FCI 70.2)
Standard: Class IV
Optional: Class V & Class VI

- Streamlined trip valves
- Compact valve design
- No-cavity design
- Quick operating time

MIL 50000

Cryogenic Valves



Standard sizes & rating
½" to 4" : ASME 150# to 2500#

Seat leakage class (as per FCI 70.2)
Standard: Class IV
Optional: Class V & Class VI

- Extended body construction
- Heavy guided extended tubular plug
- Zig-zag flow path
- Body-bonnet bolting outside the cold box

MIL 76000

High Pressure Letdown Control Valves



Standard sizes & rating
1" to 2": ASME 150# to 2500#

Seat leakage class (as per FCI 70.2)
Standard: Class IV
Optional: Class V

- High pressure letdown control valves
- Unbalanced plug design without seal rings
- Larger flow paths
- Smooth axial flow
- Multi-stage pressure reduction for high pressure drop

MIL 77000

Multi-stage Labyrinth Lo-dB Control Valves



Standard sizes & rating

2" to 8": ASME 600# to 2500#

Seat leakage class (as per FCI 70.2)

Standard: Class IV

Optional: Class V

- Anti-clog design
- Multi-stage, labyrinth plug
- Flow area expands towards the downstream
- Ideally suited for fluids involving gases with entrained liquids / solids or liquids with entrained solids
- Standardised high performance material

MIL 81000

Three Way Combining and Diverting Control Valves



Standard sizes & rating

¾" to 12": ASME 150# to ASME 2500#

Seat leakage class (as per FCI 70.2)

Standard: Class IV

Optional: Class VI

- 3-way control valves
- Combining and diverting applications
- Plug stability at throttling
- High capacity
- Extra guiding

MIL 10R-21R

Direct Operated Pressure Regulators



Standard sizes & rating

1" to 4": ASME 150# to 600#

Seat leakage class (as per FCI 70.2)

Standard: Class II / IV

- Direct operated
- Suitable for both upstream and downstream pressure control
- Top or top and bottom guided
- Variety of diaphragm material options

Actuators



MIL 37-38 Pneumatic Spring Diaphragm Actuators

Sizes: 11", 13", 15", 18" & 24"

Travel: < 4"

Supply Pressure:

20 psig to 65 psig

MIL 67-68 Piston Cylinder Actuators

Sizes: 6", 12", 16", 20" & 24"

Travel: < 12"

Supply Pressure:

60 psig to 100 psig

Electrical & Electro Hydraulic Actuators

Our control valves can be fitted with internationally reputed makes of electrical and electro hydraulic actuators

Smart Positioners



We offer Profibus / Hart / Foundation Fieldbus based smart positioners mounted on our control valves fully compatible with all major Distributed Control Systems (DCS)

Switches & Transmitters



MIL 496 Rotary Limit Switches

Used for electrically indicating one/two predetermined positions in the stroke of a control valve. They may be connected to audible alarms or signal lights for warning of valve or system malfunction or used to actuate solenoids, relays and other electrical devices.

MIL 400L Electronic Position Transmitters

Capable of transmitting angular movements as well as linear movements of control valves (with proper linkages) as 4-20 mA output signal. To ensure high accuracy levels, MIL 400L designs operates on LVDT -Linear Variable Differential Transformer- principle.

Positioners



MIL 7400 Pneumatic Positioners

Employ a force balance system to ensure that the position of the valve plug is directly proportional to the controller output pressure, regardless of packing box friction, diaphragm actuator hysteresis or off-balance forces on the valve plug.

MIL 8013 Electro Pneumatic Positioners

Provide precise and reliable valve positioning and superior dynamic response, by directly comparing valve stem position with controller DC output signal, providing dynamic response and positioning accuracy.

Your Valve Specialist

Leading Brands • **FAST TRACK** • Competitive Prices

CONTROL VALVES

Customized, Fast Track (4 weeks),
Replacement Parts

CHOKE VALVES

Customized, Fast Track (4 weeks),
Replacement Parts

PRESSURE SAFETY VALVES

Customized, Fast Track, Like for Like
Replacement, Package

BALL VALVES

Wide Stock,
Premium Quality,
API6D,
European
or US standards

RUPTURE DISCS

Customized, World Leader,
Safety

GATE GLOBE CHECK VALVES

Wide Stock,
Premium Quality,
API6D, European
or US standards

TANK PROTECTION

No Risk for your
Critical Assets

BUTTERFLY VALVES

Wide Stock,
Premium Quality, API6D,
European or US standards

REGULATORS

Air, Liquid, Gas,
Customized,
Like for Like Replacement

ACTUATORS & AUTOMATION, SDV, ESDV

Spare Parts, Customized,
Fast track, Control Panels

API6A

Wellhead Valves
and Solutions

Our locations

FRANCE Paris
ANGOLA Luanda
CAMEROON Douala
SENEGAL Dakar



ENGINEERED
PRODUCTS
& SERVICES

E.P.&S.

Your Valve Specialist in Africa

France +33 7 82 00 62 76
Cameroon +237 652 127 095
ventes@fr-eps.com
logistique@fr-eps.com
www.fr-eps.com